

PAPER • OPEN ACCESS

## Urban farming as a slum settlement solution (study on slum settlements in Tanjung Merdeka Village, Makassar City)

To cite this article: B Surya *et al* 2020 *IOP Conf. Ser.: Earth Environ. Sci.* **562** 012006

View the [article online](#) for updates and enhancements.

You may also like

- [Sustainable Approach for Slum Redevelopment in Ludhiana](#)  
Harshpreet Kaur and Mona Sood
- [Typology of Slum Management in Coastal Settlement as a Reference of Neighborhood Planning in Konawe](#)  
Santi, Ratna Bachrun and Kurniati Ornam
- [Fuzzy B-spline optimization for urban slum three-dimensional reconstruction using ENVISAT satellite data](#)  
Maged Marghany



**ECS** The Electrochemical Society  
Advancing solid state & electrochemical science & technology

**Learn More & Register**

243rd Meeting with SOFC-XVIII

Boston, MA • May 28 – June 2, 2023

**Accelerate scientific discovery!**

# Urban farming as a slum settlement solution (study on slum settlements in Tanjung Merdeka Village, Makassar City)

**B Surya<sup>1</sup>, D N A Ahmad<sup>2</sup>, R S Bahrin<sup>3</sup> and H Saleh<sup>4</sup>**

<sup>1</sup> Urban and Regional Planning Universitas Bosowa, Urip Sumoharjo Street No. 4, Makassar, 90231, Indonesia

<sup>2</sup> Urban Geography Universitas Bosowa, Urip Sumoharjo Street No. 4, Makassar, 90231, Indonesia

<sup>3</sup> Architecture Universitas Bosowa, Urip Sumoharjo Street No. 4, Makassar, 90231, Indonesia

<sup>4</sup> Regional Economic Universitas Bosowa, Urip Sumoharjo Street No. 4, Makassar, 90231, Indonesia

**Abstract.** This study aims to analyze typology, slums, and the direction and strategy for handling slums through the application of the concept of urban farming. The research method used is a combination of qualitative-quantitative approaches. Data was obtained through observations, surveys of 300 respondents and the results of documentation studies. The results of this study indicate that urban development that ignores the existence of poor and marginal communities causes slums to develop. The findings obtained in this study through path analysis show that the concept of urban farming has a value of 89.69% contribution to economic productivity in handling slums. This means that the concept of urban farming positively contributes to the economic empowerment of the community as a solution to handling slums and improving community welfare.

## 1. Introduction

Makassar as a metropolitan city has 1.489.011 population (BPS, 2018) and it is located as a main city in East of Indonesia making this a city which attracts for investors to develop large-scale settlements and centers of economic commercial activity. These conditions have an impact on excessive urbanization and over population. Building activity at the metropolitan scale reflects socioeconomic transformations increasingly dependent on place-specific factors in border cities can provide suggestions for promoting the sustainable development of border cities (You *et al.*, 2018; Zambon *et al.*, 2019). The high population growth has an impact on the acceleration of the development, changes in the pattern of spatial linkages, meeting the needs of urban infrastructure and the development of new urban areas.

The dynamics of the growth and development in Makassar City is marked by the existence of slums areas that are distributed in 15 sub-districts and 127 urban villages. The existence of slums is positively correlated with the increasing population due to urbanization and economic globalization at the micro level. As the result, the effect is very significant toward the increasing poverty as many as 30,401 households at the urban micro level. By emphasizing that the factors that contribute to slums are socio-economic conditions, the environment, uneven urban resource distribution, and wide gaps between the rich and the poor (Oluwole and Kin Wai, 2018)

Tanjung Merdeka is an area that is developed as an area of economic growth and a new city area oriented towards increasing of the economic productivity in Makassar City. The process is positively



Content from this work may be used under the terms of the [Creative Commons Attribution 3.0 licence](https://creativecommons.org/licenses/by/3.0/). Any further distribution of this work must maintain attribution to the author(s) and the title of the work, journal citation and DOI.

associated with changes in social structure, social processes, and cultural patterns of local communities. Furthermore, the spatial dynamics that developed leads to the unreachable access of local communities to seize economic opportunities due to the replacement of the traditional work system community towards the work system of industrial society (Surya, 2015). The main driver of urban growth in the past few years, has changed the social, spatial, and economic landscapes of cities but also made the urban scene much more diverse, lively, and dynamic (Qingjiu & Maliki, 2018).

The development of spatial physical changes has an impact on the development activities of residential areas, shopping centers, trade, industry, tourism and transportation. In some inner city neighborhoods, local governments and / or developers are still focusing more on exploiting commercial or tourism profits than on preserving cultural values (Chun et al., 2012). Changes in spatial use that are dominated by large-scale settlement development running with the increasing economic productivity causing changes in spatial structure, spatial patterns, and cultural patterns of the community (Surya, et al., 2015). The emergence of new classes due to changes in spatial use and social formation, causes the dynamics of the formal economy and informal economy. Nowadays, poorly planned urban expansion has led to lesser actions on environmental protection. This situation is further compounded by the difficult economic environment with tolls of urban poverty and the short-sightedness of decision makers to address the preponderant issue adequately (Suinyuy and Xiong, 2015).

Slum areas that developed in the Tanjung Merdeka Sub-District basically occurred due to the inability of the community to access the economic resources of the city and the inability to access the spatial reproduction resources causing a sharp income gap between migrants and local communities. Development of Metro Tanjung Bunga district has revolutionary influence on physical and spatial change and it significantly affects social-economic conditions of local community (Surya, 2014). One effort that can be conducted to encourage economic productivity of local communities is by handling of slums based on urban farming. The concept of urban farming that is implemented is oriented towards empowerment of economic community. This concept is used as a solution for local communities located in slums in Tanjung Merdeka Village.

The concept of urban farming as a slum solution is based on the consideration that this effort does not require special skills which means that the community will be more easily mobilized, adaptable and does not require large tracts of land. Facilitation efforts carried out in the development of these concepts are through the development patterns of hydroponic and aquaponic agriculture. Thus, the purpose of this article is to examine the direct and indirect effects of the concept of urban farming as a solution to handle slum areas in Tanjung Merdeka Village.

## **2. Methods**

Urban farming based on economic empowerment is oriented to the productivity of economic community ventures and as a strategy for handling slums. That is, this concept is more emphasized towards the subjective (Moleong, 2002; Bungin, 2016). This study is naturalistic, rationalistic, holistic, cultural, and phenomenological (Densin and Lincon, 2009; Creswell, 2016; Sugiono, 2016). The design of this study is a sequential explanatory program, beginning with an evaluation of various slum settlement management programs that have been implemented in Tanjung Merdeka Village. There are three stages of this research process, namely; (1) the field stage by understanding the background of research and self-preparation; (2) by entering the field with the aim of understanding and exploring the state of the research subject, so that the relationship between the researcher and the subject under the study is smooth; (3) by participating in the process of collecting data in the field using field notes, recording devices and confining themselves to the background of research and analysis in the field; (4) data analysis stage by using basic concepts, namely (a) organizing data that has been collected in the field, including; field notes, photographs and documents that become supplementary data in the form of reports.

The samples used in this study amounted to 50 using the purposive sampling method.

Determination of sample criteria based on slum criteria which includes road conditions, drainage, clean water, house building, sewage treatment, waste, and fire protection. This study approach uses mix methods, combining quantitative and qualitative research approaches sequentially.

The qualitative method is used to prove, deepen, expand, weaken, and invalidate the quantitative data obtained at an early stage. Quantitative method is used to test research questions, namely; (i) the effect of X1 and X2 on Y, (ii) the influence of X2 and X3 on Y, (iii) the influence of X1, X2, and Y on Z, (iv) the influence of X2, X3 and Y on Z, (v) the influence X1 and X2 through Y to Z and (vi) the influence of X2 and X3 through Y to Z using the path analysis method. The main analysis is intended to examine the construct of the path whether empirically tested or not. The next analysis is intended to determine the direct and indirect effects by using correlation and regression tests to the last dependent variable. The results are used to answer whether the results obtained must go through a direct route or through intervening variables. In testing, there are variable that has function as an intermediate path (Y). Intermediate variable is used to determine whether to reach the final goal must pass the intermediate variable or directly to the final target. Variables that are specified, namely; community participation (X1), workforce potential (X2), handling of slums (X3), urban farming solutions (Y), and economic productivity (Z).

### 3. Result and Analysis

The dynamics of the rapid and revolutionary development in Makassar City have an impact on the population which is quite high. The increasing level of development has often been attributed to urbanization. Rapid urbanization, mainly in terms of high population growth, continues to pose substantial threats to the sustainability of cities (Kaur and Luthra, 2018; Ayambire et al., 2019). This condition then raises various kinds of problems including; physical environment, social, and economy which become the basic of the formation of slums. Slums form and grow in many different parts of the world for many different reasons. Some causes include rapid rural-to-urban migration, economic stagnation and depression, high unemployment, poverty, informal economy, poor planning, politics, natural disasters and social conflicts (Ragheba et al., 2016). Tanjung Merdeka Village is a coastal area with relatively flat topography conditions and relatively low land prices. Changes in coastal characteristics due to the development activities of new urban areas have a direct impact on the socio-economic local communities.

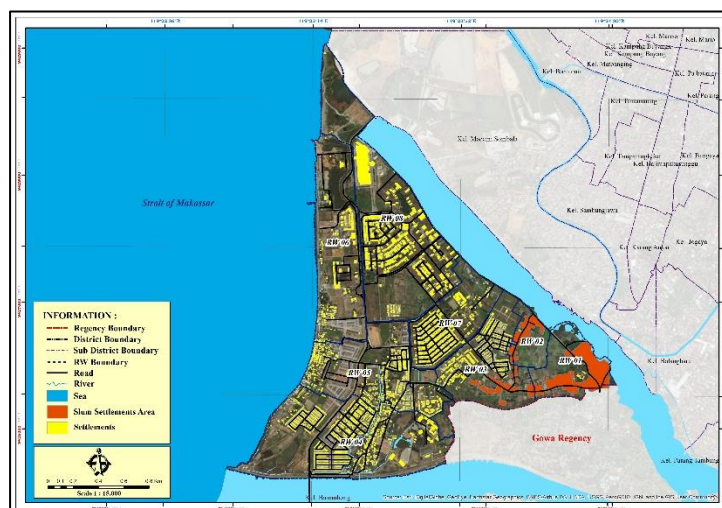
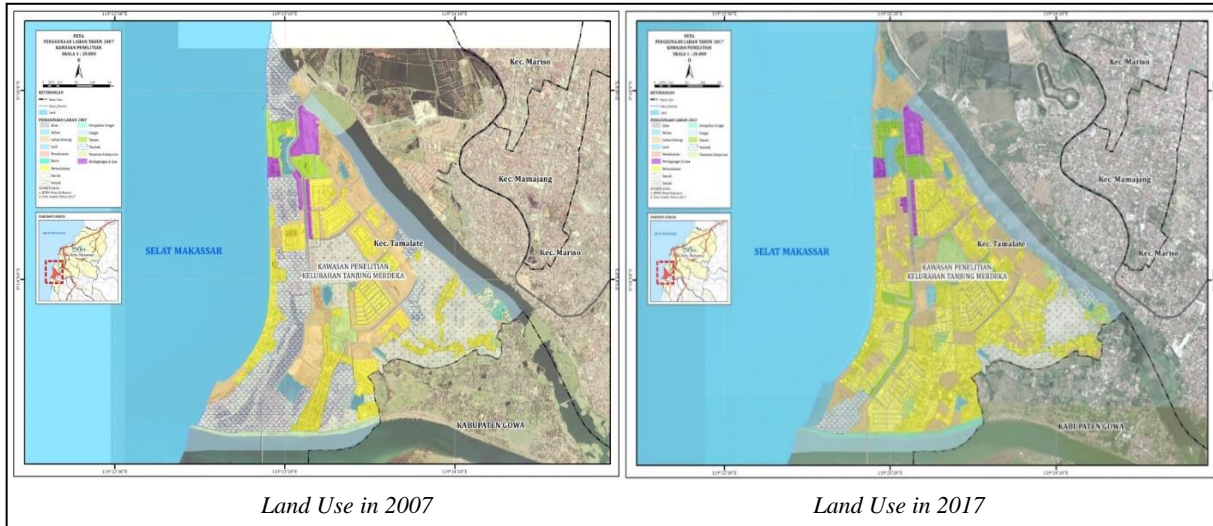

**Figure 1.** Tanjung Merdeka Village as the Research Object

Source: Authors; Map<sup>(c)</sup> 2018 Google

The Increasing of population in Tanjung Merdeka Village over the past five years, namely: (i) In 2014 the population was 10,540 people, (ii) in 2015 the population increased to 10,764 people, (iii) in 2016 the population increased to 10,981 people, (iv) in 2017 increased to 11,200 people, and (v)

in 2018 increased to 11,414 people (BPS, 2018). This fact illustrates that the population in Tanjung Merdeka Village has experienced a significant increase and is running parallel to the increase in the intensity of development towards economic growth. the changing of land usage in Tanjung Merdeka Village is shown in the following figure.



**Figure 2.** Land Use Change in Tanjung Merdeka Village  
 Source: Authors; Map<sup>®</sup> Google

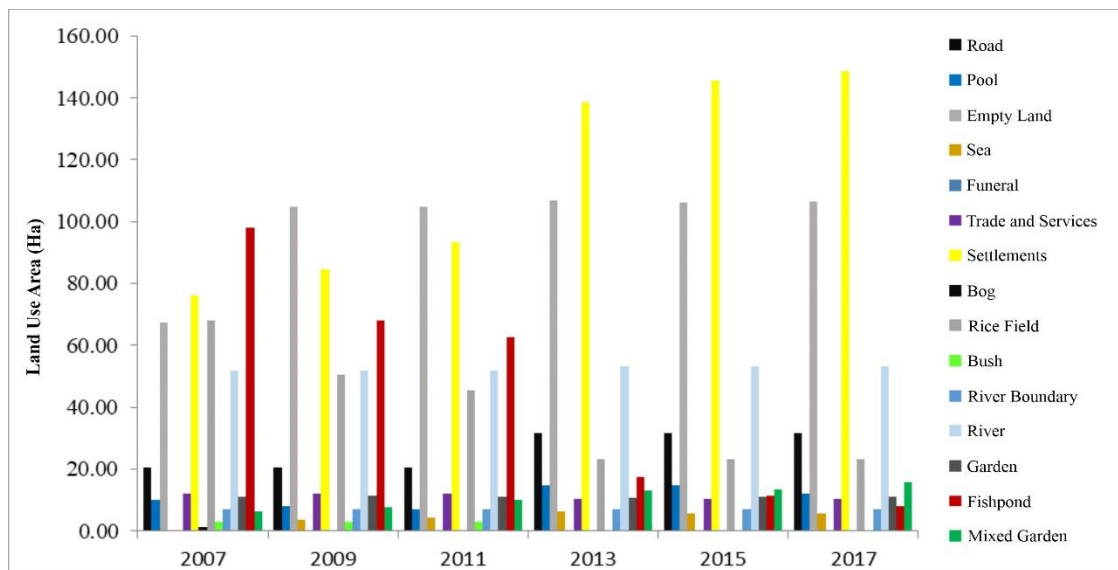

**Figure 3.** Land Use Change 2007-2017 in Tanjung Merdeka Village  
 Source: Authors; Map<sup>®</sup> Google

Figure 3, shows the changes in land use during the last ten years in Tanjung Merdeka Kelurahan and settlements are the dominant spatial use with an area of 148.70 Ha or 34.33%. The development of new settlements is positively associated with the increasing number of population and is identified to threaten the sustainability of the local workforce and sustainability of city environmental. The fact found in the field illustrates that the existence of poor communities located in slums has a tendency to build relationships between individuals as community units and economic relations that are mutually beneficial in one environmental unit. The cultural approach, which is more collaborative and participatory, draws upon valuable cultural capital and local connections to build social networks,

implementing the ideas of the residents and preserving a traditional way of life (Chun, et al., 2012).



**Figure 4.** Slum Settlements Condition in Tanjung Merdeka Village

*Source: Primary Data, 2019*

The typology of developing slums is divided into two categories, namely lowland slums and waterfront slums. The typology is based on the level of slums categorized as mild slums (Bappeda Kota Makassar, 2018). Furthermore, the total of the slum areas is 17.19 hectares in 2017 and in 2018, it is 13.18 hectares. It means that the government has contributed to the reduction in the extent of slums. Based on the results in the field it indicates that the reduction in area is only focused on improving the quality of infrastructure and tends to be partial and dominant on improving the quality of roads and environmental drainage. While social and economic problems as a whole system of environmental settlements have not been handled optimally. Thus, the problem of economic access and sociocultural relevance to the handling of slums tends to be ignored. In many cases, the handling of slums has been carried out in various countries so far, starting from the relocation of slums, environmental rejuvenation, infrastructure development, and apartment programs. Strategies tried to reduce and transform slums in different countries, with varying degrees of success, include a combination of slum removal, slum relocation, slum upgrading, and urban planning with city wide infrastructure development, and public housing projects (Ragheba et al., 2016).

In the case of the Tanjung Merdeka Village of Makassar City with reference to the facts in the field, it illustrates that the problem of slums tends to be complex. We thought that there is one solution in handling slums which is the implementation of the concept of urban farming based on economic community empowerment. The concept of urban farming has developed, taking various perspectives over time from specific purposes to consider various meanings and activities for the good of society. Urban farming is frequently promoted as a solution to food deserts by providing a local source of fresh produce (Haddad and Darwish, 2019; Poulsen, 2016). The solution of an urban farming is conceived to address the slums in Tanjung Merdeka Village completely by encouraging role for local community participation that is marginalized due to the development of new urban areas. Field facts found that the marginalization of local communities due to inability in the process of adaptation to functions that develop. The increasing of economic activities and the development of formal settlements as well as the presence of migrant populations directly impacts the formal economic access of local communities. This fact after being confirmed in the field illustrates that the inability of economic access to local communities due to limited ability, skills, and limited educational background to be absorbed in formal employment. The concept of economic empowerment which is oriented to the local community through the process of mentoring in the implementation of urban farming through a hydroponic pattern will

encourage increased productivity, employment, and added value economically without requiring special skills and expertise as well as adequate educational background. Below is the results of the path analysis of urban farming concept based on economic empowerment.

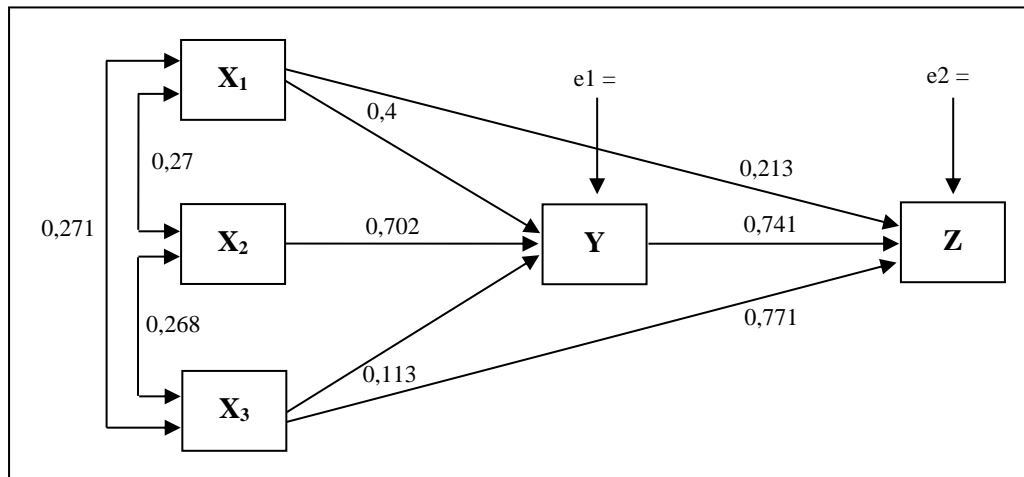
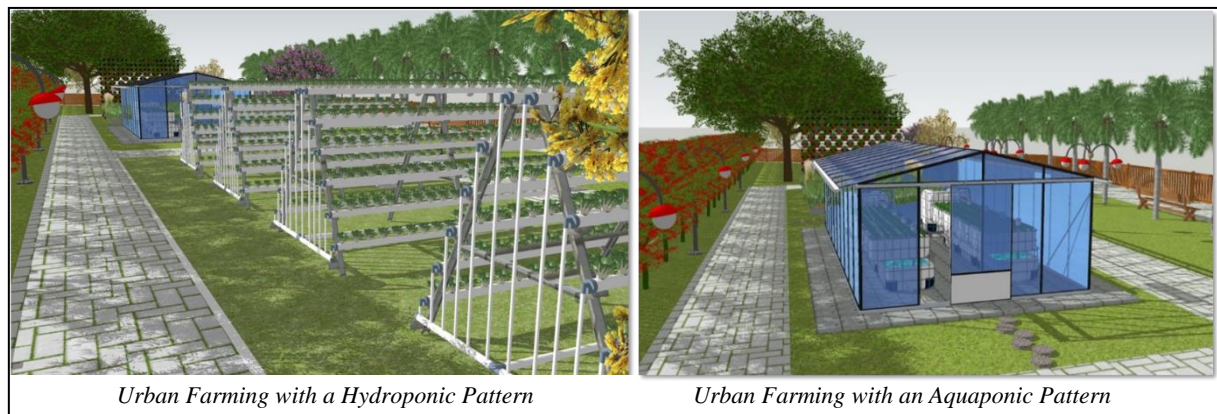

**Figure 5.** Relationship Between Urban Farming Towards Handling Slums

Source: Analysis Result, 2019

Figure 5 shows the relationship or correlation of urban farming solutions based on economic empowerment community to handle slums. Some interpretation that can be submitted to the results of the analysis are: (i) Relationship or correlation between community participation to the potential workforce of 0.27, (ii) Relationship or correlation between community participation in the handling of slums by 0.271, (iii) Relationship or the correlation between the potential of the workforce and the handling of slums by 0.268. Furthermore, the direct effect of urban farming on the handling of slums that can be explained, namely; (i) the direct effect of community participation on urban farming  $(0.41)^2 = 0.1681 = 16.81\%$ , (ii) the direct effect of the potential workforce on urban farming  $(0.702)^2 = 0.4928 = 49.28\%$ , (iii) the direct effect of handling slums on urban farming  $(0.113)^2 = 0.0128 = 1.28\%$ .

Furthermore, the indirect effect of handling slums based on urban farming, namely: (i) community participation through urban farming on economic productivity  $(0.41)(0.27)(0.702) = 0.0777 = 7.77\%$ , (ii) potential labor force through urban farming towards community participation  $(0.702)(0.27)(0.41) = 0.0777 = 7.77\%$ , (iii) community participation through handling of slums to urban farming  $(0.41)(0.271)(0.113) = 0.0126 = 1.26\%$ , (iv) urban farming through the handling of slums against community participation  $= (0.113)(0.271)(0.41) = 0.0126 = 1.26\%$ , (v) the potential of the labor force through handling of slums to urban farming  $= (0.702)(0.268)(0.113) = 0.0213 = 2.13\%$ , (vi) handling of slums through the potential of the labor force against urban farming  $= (0.113)(0.268)(0.702) = 0.0213 = 2.13\%$ . Overall, the total effect was obtained  $(0.1681 + 0.4928 + 0.0128) + (0.0777 + 0.0777) + (0.0126 + 0.0126) + (0.0213 + 0.0213) = 0.8969$  or 89.69%. The remaining influence or residue (the influence of other independent variables is not examined on urban farming) is  $1 - 0.8969 = 0.1031 = 10.31\%$ . Based on this result, it can be justified that urban farming has a positive influence on economic productivity in the handling slums. As for the direct effect of urban farming on economic productivity  $(0.741)^2 = 0.5491 = 54.91\%$ . The remaining influence or residue (the influence of other variables on economic productivity) is  $1 - 0.5491 = 0.4509 = 45.09\%$ . Overall, the results obtained that the effect of X on Y is around 89.69% and the effect of Y on Z is about 54.91%. The following figure patterns are presented hydroponic agricultural illustration that can be developed in Tanjung Merdeka Village.



**Figure 6.** Urban Farming Design in Tanjung Merdeka Village

Source: Analysis Result, 2019

Figure 6 shows the pattern of urban farming activities developed in Tanjung Merdeka Village which is oriented towards hydroponics and aquaponics manufacturing. The material plan used in the manufacture of hydroponics is a type of PVC pipe with a diameter of 21/2. Provision of aquaponics developed utilizing the potential flow of the Je'neberang River and combined with developing aquaculture with a floating net cage system. Thus, the aquaponic pattern is also used as an alternative offer in the development of fish farming based on increasing the productivity of the community's economic efforts.

#### 4. Conclusion

The implementation of the concept of urban farming based on economic empowerment contributes positively to the increasing economic productivity community, absorbing of the workforce, and reducing the extent of slums. Urban farming in its application will require active involvement of the community, ongoing assistance will encourage the sustainability of local economic ventures, job creation and improvement of community welfare.

#### 5. References

- [1] Ayambire, Raphael Anammasiya., Amponsah, Owusu., Pephrah, Charles., and Takyi, Stephen Appiah. 2019. *A Review of Practices for Sustaining Urban and Peri-Urban Agriculture: Implications for Land Use Planning in Rapidly Urbanising Ghanaian Cities*. Journal of Land Use Policy. Vol.84.pp.260-277. <https://doi.org/10.1016/j.landusepol.2019.03.004>
- [2] Badan Pusat Statistik. 2018. Kecamatan Tamalate dalam Angka 2018. BPS Kota Makassar
- [3] Bungin, B. 2016. *Penelitian Kualitatif. Edisi Kedua. Komunikasi, Ekonomi, Kebijakan Publik dan Ilmu Sosial Lainnya*. Penerbit. Prenada Media Group.
- [4] Creswell, J.W. 2016. *Research Design. Pendekatan Metode Kualitatif, Kuantitatif, dan Campuran*. Edisi 4. Penerbit. Pustaka Pelajar.
- [5] Chun Zhang, et al., 2012. *Involving the Community in Inner City Renewal: A Case Study of Nanluogu in Beijing*. Journal of Urban Management. ELSEVIER. Volume. 1. Issue 2. 2012. pp. 53-71. [https://doi.org/10.1016/S2226-5856\(18\)30060-8](https://doi.org/10.1016/S2226-5856(18)30060-8)
- [6] Denzin and Lincoln., 2009. *Hand Book of Qualitative Research*. Penerbit. Pustaka Pelajar.
- [7] Haddad, Rema and Darwish, Zelal. 2019. *Urban Farming and Its Role in Enhancing the Sustainability of Cities*. Sustainable Cities and Communities, Encyclopedia of the UN Sustainable Development Goals. SPRINGER. [https://doi.org/10.1007/978-3-319-71061-7\\_41-1](https://doi.org/10.1007/978-3-319-71061-7_41-1)
- [8] Kaur, Ritu Raj and Luthra, Ashwani. 2018. *Population Growth, Urbanization and Electricity – Challenges and Initiatives in the State of Punjab, India*. Energy Strategy Reviews. ELSEVIER. Vol 21pp50-61. DOI: 10.1016/j.esr.2018.04.005



- [9] Moeleong J.L., 2002. *Metodologi Penelitian Kualitatif*. Penerbit. PT. Remaja Rosdakarya. Sugiyono., (2016). *Metode Penelitian dan Pengembangan. Untuk Bidang: Pendidikan, Manajemen, Sosial dan Teknik*. Penerbit. Alfabeta. Bandung.
- [10] Poulsen, Melissan N. 2017. *Cultivating Citizenship, Equity, and Social Inclusion? Putting Civic Agriculture Into Practice Through Urban Farming*. Journal of Agriculture and Human Values. SPRINGER. Vol.34. pp.1.35-148. <https://doi.org/ezproxy.ugm.ac.id/10.1007/s10460-016-9699-y>
- [11] Ragheb, Ghada., El Shimy, Hisham., and Ragheb, Amany. 2016. Land for Poor: Towards Sustainable Master Plan for Sensitive Redevelopment of Slums. *Procedia – Sosial and Behavioral Sciences*. Vol 216.pp 417-427. DOI: 10.1016/j.sbspro.2015.12.056
- [12] Suinyuy D.N. and Xiong Zhi Xue., 2015. *Addressing urban sprawl in Douala, Cameroon: Lessons from Xiamen integrated coastal management*. Journal of Urban Management. ELSEVIER. Volume 4. Issue 1. pp.53-72. <https://doi.org/10.1016/j.jum.2015.05.001>
- [13] Surya, Batara. 2014. *Social Change, Spatial Articulation in the Dynamics of Boomtown Construction and Development Case Study of Metro Tanjung Bunga Boomtown, Makassar*. Canadian Center of Science and Education. Modern Applied Science. Volume 8. pp.238-245. <http://dx.doi.org/10.5539/mas.v8n4p238>
- [14] Surya, Batara. 2015. *Spatial Articulation and Co-Existence of Mode of Production in the Dynamics of Development at the Urban Fringe of Makassar City*. Medwell Journal. Journal of Engineering and Applied Science. Volume.10. Issue 8. pp.214-222. [10.3923/jeasci.2015.214.222](https://doi.org/10.3923/jeasci.2015.214.222)
- [15] Oluwole Soyinka, and Kin Wai Michael Siu., 2018. *Urban informality, housing insecurity, and social exclusion; concept and case study assessment for sustainable urban development*. City, Culture and Society. Elsevier. Volume 15.pp. 23-36. <https://doi.org/10.1016/j.ccs.2018.03.005> <https://doi.org/10.1016/j.ccs.2018.03.005>
- [16] Qingjiu & Nor Zarifah Maliki., 2018. *Rural-Urban Migrants' Sense of Place In The City of Baoding, China*. Planning Malaysia. Vol. 16. Issue. 4. pp. 68-80. <http://dx.doi.org/10.21837/pmjournal.v16.i8.539>
- [17] You, Zhen., Yang, Hanbing., and Fu Meichen. 2018. *Settlement Intention Characteristics and Determinants in Floating Population in Chinese Border Cities*. Sustainable Cities and Society. ELSEVIER. Vol.39.pp.476-486. <https://doi.org/10.1016/j.scs.2018.02.021>
- [18] Zambon, Ilaria., Coalntoni, Andrea., Salvati, Luca. 2019. *Horizontal VS Vertical Growth: Understanding Latent Patterns of Urban Expansion in Large Metropolitan Regions*. Science of the Total Environment. ELSEVIER. Vol.654.pp.778-785. <https://doi.org/10.1016/j.scitotenv.2018.11.182>