

TUGAS AKHIR

ANALISIS KEBUTUHAN RUANG PARKIR BERDASARKAN LAMA PARKIR AKIBAT PERLUASAN BANDARA INTERNASIONAL SULTAN HASANUDDIN

Diajukan untuk memenuhi salah satu syarat memperoleh Gelar

Sarjana Teknik Strata Satu

(S1)



Disusun oleh :

MARADONA PANJAITAN

45 18 041 126

**PROGRAM STUDI TEKNIK SIPIL
JURUSAN SIPIL FAKULTAS TEKNIK
UNIVERSITAS BOSOWA MAKASSAR**

2023



LEMBAR PENGAJUAN UJIAN TUTUP TUGAS AKHIR

Judul :

**“Analisis Kebutuhan Ruang Parkir Berdasarkan Lama Parkir Akibat
Perluasan Bandara Internasional Sultan Hasanuddin”**

Disusun dan diajukan oleh :

Nama : **MARADONA PANJAITAN**

STB : **45 18 041 126**

Sebagai salah satu syarat untuk memperoleh gelar Sarjana pada Program Studi Teknik Sipil / Jurusan Sipil Fakultas Teknis Universitas Bosowa Makassar.

Telah disetujui Komisi / Tim Pembimbing :

Pembimbing I : **Tamrin Mallawangeng, ST. MT** (.....)

Pembimbing II : **Ir. Satriawati C M.Sp** (.....)

Mengetahui,

Dekan Fakultas Teknik
Universitas Bosowa

Ketua Program Studi Teknik Sipil
FT. Universitas Bosowa

Dr. H. Nasrullah, ST. MT.
NIDN: 09 080773 01

Dr. Ir. A. Rumpang Yusuf, MT.
NIDN: 00 010565 02



LEMBAR PENGESAHAN TUGAS AKHIR

Berdasarkan Surat Keputusan Dekan Fakultas Teknik Universitas Bosowa Nomor : A-174/FT/UNIBOS/II/2023 tanggal 17 Februari 2023 perihal Pengangkatan Panitia Dan Tim Penguji Tugas Akhir, maka pada :

Hari / tanggal : Jumat / 17 Februari 2023

Nama Mahasiswa : **MARADONA PANJAITAN**

No. Stambuk : **45 18 041 126**

Judul Tugas Akhir : **ANALISIS KEBUTUHAN RUANG PARKIR
BERDASARKAN LAMA PARKIR AKIBAT PERLUASAN
BANDARA INTERNASIONAL SULTAN HASANUDDIN**

Telah diterima dan disahkan oleh Panitia Ujian Sarjana Fakultas Teknik Universitas Bosowa setelah dipertahankan didepan tim Penguji Ujian Sarjana Strata Satu (S1) untuk memenuhi salah satu syarat guna memperoleh Gelar Sarjana Teknik pada Jurusan Sipil Fakultas Teknik Universitas Bosowa.

TIM PENGUJI TUGAS AKHIR

Ketua : **Tamrin Mallawangeng, ST. MT**

Sekretaris : **Ir. Satriawati C M.Sp**

Anggota : **1. Ir. H. Abd. Rahim Nurdin, MT**

2. Nurhadijah Yunianti, ST. MT

()

()

()

()

Makassar, 17 Februari 2023

Mengetahui

Dekan Fakultas Teknik
Universitas Bosowa

Ketua Program Studi Teknik Sipil
FT. Universitas Bosowa

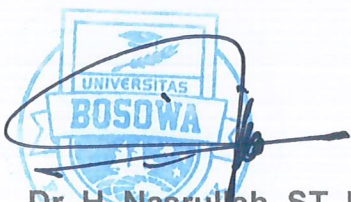
Dr. H. Nasrullah, ST. MT.
NIDN : 09 080773 01

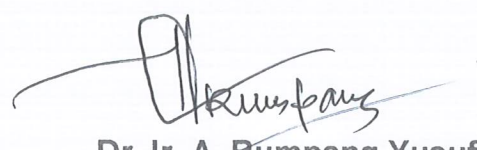
Dr. Ir. A. Rumpang Yusuf, MT.
NIDN : 00 010565 02

SURAT PERNYATAAN KEASLIAN DAN PUBLIKASI TUGAS AKHIR

Yang bertanda tangan dibawah ini :

Nama : **MARADONA PANJAITAN**
Nomor Stambuk : 45 18 041 126
Program Studi : Teknik Sipil
Judul Tugas Akhir : Analisis Kebutuhan Ruang Parkir Berdasarkan Lama Parkir Akibat Perluasan Bandara Internasional Sultan Hasanuddin

Menyatakan dengan sebenarnya bahwa :

1. Tugas akhir yang saya tulis ini merupakan hasil karya sendiri dan sepanjang pengetahuan saya tidak terdapat karya atau hasil pendapat yang pernah ditulis atau diterbitkan orang lain, kecuali secara tertulis diacu dalam naskah dan disebutkan dalam daftar pustaka.
2. Demi pengembangan pengetahuan, saya tidak keberatan apabila Jurusan Sipil Fakultas Teknik Universitas Bosowa menyimpan, mengalih mediakan / mengalih formatkan, mengolah dalam bentuk data base, mendistribusikan dan menampilkan untuk kepentingan akademik.
3. Bersedia dan menjamin untuk menanggung secara pribadi tanpa melibatkan pihak Jurusan Sipil Fakultas Teknik Universitas Bosowa dari semua bentuk tuntutan hukum yang timbul atas pelanggaran hak cipta dalam tugas akhir ini

Demikian pernyataan ini saya buat dengan sesungguhnya untuk dapat digunakan sebagaimana mestinya.

Makassar, Februari 2023

Yang menyatakan

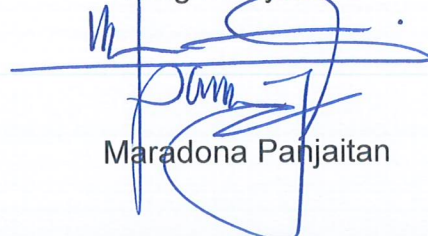
Maradona Panjaitan

PRAKATA

Puji syukur kepada Tuhan Yang Maha Esa atas berkat dan kasih-Nya sehingga penulis dapat menyelesaikan tugas akhir yang berjudul “Analisis Kebutuhan Ruang Parkir Berdasarkan Lama Parkir Akibat Perluasan Bandara Internasional Sultan Hasanuddin”. Penulisan tugas akhir ini dimaksudkan untuk memenuhi persyaratan guna memperoleh gelar Sarjana Jurusan Teknik Sipil, Fakultas Teknik Universitas Bosowa Makassar. Dalam penulisan laporan tugas akhir ini, penulis telah banyak mendapat bantuan, dorongan, doa, dan saran dari berbagai pihak, oleh karena itu pada kesempatan ini dengan segala kerendahan hati penulis ingin mengucapkan banyak terima kasih kepada :

1. Bapak Prof. Dr. Ir. Batara Surya, S.T., M.Si., selaku Rektor Universitas Bosowa;
2. Bapak Dr. Ir. A. Nasrullah, ST. MT., selaku Dekan Fakultas Teknik Universitas Bosowa;
3. Bapak Dr. Ir. A. Rumpang Yusuf, MT., selaku Ketua Jurusan Teknik Sipil, Fakultas Teknik, Universitas Bosowa Makassar.
4. Bapak Tamrin Mallawangeng, ST. MT., selaku Pembimbing I dan Ibu Ir. Satriawati C M.Sp., selaku Pembimbing II. Yang telah memberikan banyak masukan dan saran hingga tugas akhir ini dapat selesai dengan baik.

5. Bapak/Ibu dosen serta staf Jurusan Teknik Sipil Universitas Bosowa Makassar.
6. PT. Angkasa Pura I dan PT. Angkasa Pura Support.
7. Kedua orang tua dan keluarga yang terus memberi semangat dan doa untuk penulis.
8. Sahabat-sahabat penulis yang juga turut serta memberi semangat dan doa untuk penulis.
9. Teman-teman seperjuangan di Universitas Bosowa Makassar.
10. Semua pihak yang tidak dapat penulis sebutkan satu-persatu yang telah membantu hingga selesainya tugas akhir ini.

Akhir kata semoga tugas akhir ini dapat bermanfaat bagi kita semua khususnya dalam dunia pendidikan Teknik Sipil bidang Transportasi.

Makassar, Februari 2023

Penulis

ABSTRAK

Bandara Internasional Sultan Hasanuddin mengalami pertumbuhan rata-rata penumpang dan pergerakan pesawat periode tahun 2014 – 2018 masing-masing 11,35% dan 9,29% per tahun. Oleh karena itu, guna meningkatkan pelayanan sedang dilakukan pengembangan Bandar Udara mengacu Rencana Induk Bandar Udara Sultan Hasanuddin diantaranya adalah gedung parkir untuk roda 4 dengan kapasitas 624 SRP, sedangkan kapasitas parkir eksisting roda 4 adalah 1.072 SRP. Sehingga dilakukan pengumpulan data jumlah penumpang jam sibuk, data jumlah kendaraan dan data durasi parkir tiap kendaraan pada tahun 2018 sebelum dilakukan pengembangan bandara. Dari data tersebut dilakukan perhitungan kebutuhan ruang parkir pada saat jam sibuk serta perhitungan ketersediaan dan kebutuhan ruang parkir berdasarkan lama parkir tiap kendaraan. Sehingga diperoleh kebutuhan ruang parkir pada jam sibuk sebanyak 1.183 SRP, dan kapasitas yang dibutuhkan berdasarkan karakteristik lama parkir tiap kendaraan adalah 989 SRP/jam. Sedangkan yang dikembangkan saat ini adalah 624 SRP dengan kapasitas berdasarkan karakteristik lama parkir tiap kendaraan adalah 522 SRP./jam. Dari hasil perhitungan tersebut dapat disimpulkan bahwa pengembangan tahap 1 tidak mampu melayani kebutuhan parkir pada jam sibuk, sehingga diperlukan penambahan kapasitas ruang parkir.

Kata Kunci : Jam Sibuk, Ruang Parkir, SRP (Satuan Ruang Parkir).

ABSTRACT

Sultan Hasanuddin International Airport experienced an average growth in passengers and aircraft movements for the 2014-2018 period, respectively 11.35% and 9.29% per year. Therefore, in order to improve service, airport development is being carried out referring to the Sultan Hasanuddin Airport Master Plan, including a parking building for 4-wheelers with a capacity of 624 SRP, while the existing 4-wheeled parking capacity is 1,072 SRP. So that data was collected on the number of passengers during peak hours, data on the number of vehicles and data on the duration of each vehicle's parking in 2018 before the airport development was carried out. From these data, a calculation of the need for parking space is carried out during peak hours as well as a calculation of the availability and need for parking space based on the length of time each vehicle is parked. So that the need for parking space during peak hours is 1,183 SRP, and the required capacity based on the characteristics of the length of time each vehicle is parked is 989 SRP/hour. While currently being developed is 624 SRP with a capacity based on the long parking characteristics of each vehicle is 522 SRP./hour. From the results of these calculations it can be concluded that the development of stage 1 is not able to serve parking needs during peak hours, so that additional parking space capacity is needed.

Keywords : Peak Hour, Parking Spaces, SRP (Parking Space Units)

DAFTAR ISI

HALAMAN JUDUL.....	i
LEMBAR PENGAJUAN UJIAN TUTUP	ii
LEMBAR PENGESAHAN TUGAS AKHIR	iii
SURAT PERNYATAAN KEASLIAN DAN PUBLIKASI	iv
PRAKATA	v
ABSTRAK	vii
DAFTAR ISI	ix
DAFTAR GAMBAR	ixii
DAFTAR TABEL	ixiv
BAB I PENDAHULUAN.....	I-1
1.1. LATAR BELAKANG	I-1
1.2. RUMUSAN MASALAH	I-4
1.3. TUJUAN DAN MANFAAT PENELITIAN	I-4
1.3.1. Tujuan Penulisan	I-4
1.3.2. Manfaat Penelitian	I-5
1.4. POKOK PEMBAHASAN DAN BATASAN MASALAH.....	I-5
1.4.1. Pokok Pembahasan	I-5
1.4.2. Batasan Masalah	I-5
1.5. SISTEMATIKA PENULISAN.....	I-6
BAB II TINJAUAN PUSTAKA	II-1
2.1 PENGERTIAN PARKIR	II-1

2.2	JENIS FASILITAS PARKIR	II-3
2.2.1	Fasilitas Parkir Pada Badan Jalan (<i>on street parking</i>)	II-3
2.2.2	Fasilitas Parkir Diluar Badan Jalan (<i>off street parking</i>)	II-4
2.3	KEBUTUHAN TEMPAT PARKIR PADA BANDAR UDARA.....	II-6
2.4	PENENTUAN SATUAN RUANG PARKIR (SRP)	II-7
2.4.1	Dimensi Kendaraan Standar Untuk Mobil Penumpang	II-7
2.4.2	Ruang Bebas Kendaraan Parkir.....	II-8
2.4.3	Lebar Bukaannya Pintu Kendaraan	II-8
2.5	KARAKTERISTIK PARKIR	II-12
2.5.1	Kapasitas Parkir	II-12
2.5.2	Volume Parkir.....	II-13
2.5.3	Akumulasi Parkir	II-13
2.5.4	Durasi Parkir	II-14
2.5.5	Indeks Parkir	II-14
2.5.6	Pergantian Parkir (Parking Turnover).....	II-15
2.5.7	Akumulasi Parkir Rata-Rata.....	II-15
2.5.8	Satuan Ruang Parkir.....	II-16
2.6	DESAIN PARKIR DI LUAR BADAN JALAN	II-16
2.6.1	Taman Parkir.....	II-16
BAB III METODOLOGI PENELITIAN.....		III-1
3.1.	METODE PENELITIAN	III-1
3.2.	LOKASI DAN WAKTU PENELITIAN	III-1
3.2.1.	Gambaran Umum Lokasi Penelitian.....	III-1

3.2.1.	Waktu Penelitian	III-2
3.3.	TAHAPAN PENELITIAN.....	III-3
3.4.	METODE PENGUMPULAN DATA	III-4
3.4.1	Teknik Pengumpulan Data	III-4
3.5.	PEROLEHAN DATA	III-5
BAB IV HASIL DAN PEMBAHASAN		IV-1
4.1	DATA LAPANGAN.....	IV-1
4.1.1	Data Pertumbuhan Bandara.....	IV-1
4.1.2	Data Penumpang Jam Sibuk.....	IV-3
4.1.3	Data Kendaraan	IV-6
4.1.4	Data Durasi Parkir	IV-8
4.2	ANALISA DATA.....	IV-37
4.2.1	Kebutuhan Tempat Parkir Pada Bandar Udara Sultan Hasanuddin	IV-37
4.2.2	Kapasitas Tempat Parkir Eksisting Sebelum Pengembangan Bandara Internasional Sultan Hasanuddin	IV-38
4.2.3	Analisis Karakteristik Parkir.....	IV-39
BAB V KESIMPULAN DAN SARAN		V-1
5.1	KESIMPULAN.....	V-1
5.2	SARAN	V-1
DAFTAR PUSTAKA		
LAMPIRAN		

DAFTAR GAMBAR

Gambar 2 - 1 Tempat Parkir Kendaraan.....	II-2
Gambar 2 - 2 Tempat Parkir Pada Badan Jalan	II-4
Gambar 2 - 3 Taman Parkir	II-5
Gambar 2 - 4 Gedung Parkir.....	II-5
Gambar 2 - 5 Dimensi Kendaraan	II-7
Gambar 2 - 6 Satuan Ruang Parkir (SRP) untuk Mobil Penumpang (dalam cm).....	II-10
Gambar 2 - 7 Satuan Ruang Parkir (SRP) untuk Bus/Truk (dalam cm).....	II-11
Gambar 2 - 8 Satuan Ruang Parkir (SRP) untuk Sepeda Motor (dalam cm)	II-12
Gambar 2 - 9 Parkir Satu Sisi Dengan Sudut 90^0	II-17
Gambar 2 - 10 Parkir Satu Sisi Dengan Sudut 30^0 , 45^0 , 60^0	II-18
Gambar 2 - 11 Parkir Dua Sisi Dengan Sudut 90^0	II-18
Gambar 2 - 12 Parkir Dua Sisi Dengan Sudut 30^0 , 45^0 , 60^0	II-19
Gambar 2 - 13 Parkir Pulau Dengan Sudut 90^0	II-19
Gambar 2 - 14 Parkir Pulau Dengan Sudut 45^0 Tipe A.....	II-20
Gambar 2 - 15 Parkir Pulau Dengan Sudut 45^0 Tipe B.....	II-20
Gambar 2 - 16 Parkir Pulau Dengan Sudut 45^0 Tipe B.....	II-20
Gambar 2 - 17 Parkir Bus/Truk Satu Sisi.....	II-21
Gambar 2 - 18 Parkir Bus/Truk Satu Sisi	II-21

Gambar 2 - 19 Parkir Sepeda Motor Satu Sisi.....	II-22
Gambar 2 - 20 Parkir Sepeda Motor Satu Sisi.....	II-22
Gambar 2 - 21 Parkir Sepeda Motor Pulau.....	II-23
Gambar 2 - 22 Gang dan Modul	II-24
Gambar 2 - 23 Pintu Masuk dan Pintu Keluar Terpisah.....	II-25
Gambar 2 - 24 Pintu Masuk dan Pintu Keluar Menjadi Satu.....	II-26
Gambar 2 - 25 Pintu Masuk dan Pintu Keluar Terpisah Pada Satu Ruas Jalan	II-27
Gambar 3 - 1 Layout Bandara Internasional Sultan Hasanuddin.....	III-2
Gambar 3 - 2 Bagan Alir Penelitian	III-3
Gambar 4 - 1 Grafik Pertumbuhan Pesawat.....	IV-2
Gambar 4 - 2 Grafik Pertumbuhan Penumpang	IV-2
Gambar 4 - 3 Grafik Pertumbuhan Kargo & Pos.....	IV-2
Gambar 4 - 4 Grafik Peak Hour Penumpang Tahun 2018.....	IV-5

DAFTAR TABEL

Tabel 2. 1 Persyaratan Area Luas Parkir	II-6
Tabel 2. 2 Lebar Buka an Pintu Kendaraan	II-9
Tabel 2. 3 Penentuan Satuan Ruang Parkir (SRP).....	II-10
Tabel 2. 4 Lebar Jalur Gang	II-24
Tabel 3. 1 Jadwal Pelaksanaan Penelitian	III-2
Tabel 3. 2 Data Pertumbuhan Bandara Sultan Hasanuddin	III-5
Tabel 4. 1 Data Pertumbuhan Bandara Sultan Hasanuddin	IV-1
Tabel 4. 2 Data Peak Hour Penumpang Tahun 2018	IV-4
Tabel 4. 3 Data Pergerakan Kendaraan Harian Bulan Desember 2018	IV-6
Tabel 4. 4 Data Pergerakan Kendaraan Harian Bulan Juli 2018	IV-7
Tabel 4. 5 Durasi Parkir Kendaraan Harian	IV-8
Tabel 4. 6 Tabel Durasi Parkir Rata-Rata	IV-39

BAB I

PENDAHULUAN

1.1. LATAR BELAKANG

Pada era pembangunan ini, kebutuhan pelayanan jasa transportasi terus meningkat, khususnya permintaan jasa transportasi udara. Transportasi udara mampu menempuh jarak jauh, bergerak cepat dan dapat menembus ke wilayah yang tidak dapat dijangkau oleh sarana transportasi lainnya. Transportasi udara mampu membuka terisolasinya suatu daerah, sehingga dapat menunjang kelancaran pembangunan. Demikian pentingnya sektor transportasi udara ini, sehingga pemerintah dituntut untuk memenuhi permintaan terhadap pelayanan jasa transportasi baik dari segi sarana maupun prasarananya.

Transportasi udara digunakan hampir di semua bidang, diantaranya pada bidang ekonomi, sosial maupun pertahanan dan keamanan. Bandar udara merupakan prasarana penting dalam menunjang pelayanan jasa transportasi udara, karena merupakan tempat pergerakan pesawat untuk mendarat maupun lepas landas, tempat bongkar dan muat kargo dan aktivitas lainnya yang mendukung pelayanan jasa kebandarudaraan. Dengan perkembangan dunia penerbangan yang sangat pesat tersebut, menandakan bahwa transportasi udara memegang peranan yang sangat penting.

Bandar Udara Internasional Sultan Hasanuddin merupakan bandara kelas I yang terletak di Kabupaten Maros dan Kota Makassar Provinsi Sulawesi Selatan dengan titik referensi Bandar udara/*Aerodrome Reference Point (ARP)* pada koordinat $05^{\circ} 03' 39,383''$ LS dan $119^{\circ} 33' 16,753''$ BT dengan titik ujung landas pacu I berukuran 2.500 m x 45 m dengan azimuth 13 – 31 dan landas pacu II berukuran 3.100 m x 45 m dengan azimuth 03 – 21.

Dari data pergerakan Bandar Udara Sultan Hasanuddin, pertumbuhan jumlah penumpang dan pergerakan pesawat meningkat dari tahun ke tahun. Pertumbuhan rata-rata penumpang dan pergerakan pesawat periode tahun 2014 – 2018 tumbuh masing-masing 11,35% dan 9,29% per tahun. Banyaknya jumlah penumpang yang menggunakan pesawat secara langsung akan meningkatkan pergerakan orang yang ada di bandara, baik pengantar dan penjemput serta kendaraan yang digunakan ke bandara. Oleh karena itu, guna meningkatkan pelayanan Bandar Udara seiring pertumbuhan jumlah penumpang dan pergerakan pesawat, sedang dilakukan pengembangan Bandar Udara mengacu Rencana Induk Bandar Udara Sultan Hasanuddin Makassar (Keputusan Menteri Perhubungan KM Nomor 48 Tahun 2019 Tentang Rencana Induk Bandar Udara Sultan Hasanuddin di Kabupaten Maros Provinsi Sulawesi Selatan – Terlampir).

Dalam pengembangan tersebut salah satu yang dilaksanakan adalah fasilitas tempat parkir kendaraan. Sebelum pengembangan luas

tempat parkir di Bandar Udara Internasional Sultan Hasanuddin adalah sebagai berikut, tempat parkir kendaraan roda 4 adalah 42.869 m² dengan kapasitas 1.072 satuan ruang parkir dan tempat parkir roda 2 adalah 4.869 m² dengan kapasitas 1.345 satuan ruang parkir.

Sehubungan dengan dilakukannya pengembangan tempat parkir kendaraan diharapkan mampu mendukung kebutuhan parkir minimal sesuai dengan kondisi eksisting sebelum dikembangkan. Adapun sebagai perbedaan adalah bahwa tempat parkir eksisting merupakan lahan parkir sedangkan yang sedang dikembangkan adalah gedung parkir. Oleh karena itu perlu perhitungan yang baik dalam menghitung jumlah kapasitas tempat parkir yang disediakan kepada pengguna jasa bandar udara, baik dari segi pola parkir maupun luasan parkir. Adapun perhitungan kapasitas ruang parkir erat kaitannya terhadap lama parkir sebuah kendaraan. Semakin lama sebuah kendaraan parkir maka semakin banyak pula ruang parkir yang dibutuhkan untuk memenuhi kebutuhan parkir dengan volume kendaraan yang sama, dan sebaliknya.

Berdasarkan uraian masalah tersebut, maka judul tugas akhir yang diangkat adalah **“ANALISIS KEBUTUHAN RUANG PARKIR BERDASARKAN LAMA PARKIR AKIBAT PERLUASAN BANDARA INTERNASIONAL SULTAN HASANUDDIN”**.

1.2. RUMUSAN MASALAH

Sesuai dengan uraian latar belakang diatas dapat disimpulkan bahwa tempat parkir kendaraan bandar udara harus mampu menampung volume pergerakan kendaraan yang ada di Bandar Udara Internasional Sultan Hasanuddin (terkhusus kendaraan roda 4). Sehingga dapat dirumuskan masalah-masalah sebagai berikut :

1. Apakah pengembangan tempat parkir kendaraan Bandar Udara Internasional Sultan Hasanuddin mampu menampung volume kendaraan yang parkir akibat perluasan terminal bandara yang sedang dilaksanakan (pengembangan Tahap 1)?
2. Apakah kapasitas yang dikembangkan mampu menampung kendaraan sesuai lama parkir tiap kendaraan?

1.3. TUJUAN DAN MANFAAT PENELITIAN

1.3.1. Tujuan Penulisan

Sesuai dengan rumusan masalah yang ditetapkan, maka tujuan yang akan dicapai dalam penelitian ini adalah sebagai berikut :

1. Untuk menganalisis pengembangan tempat parkir tahap 1 di Bandar Udara Internasional Sultan Hasanuddin mampu menampung kebutuhan parkir kendaraan.
2. Untuk mengetahui kapasitas dan kebutuhan parkir kendaraan di Bandar Udara Internasional Sultan Hasanuddin saat ini sesuai lama parkir tiap kendaraan.

1.3.2. Manfaat Penelitian

Adapun manfaat dari penelitian ini adalah sebagai berikut :

1. Memberikan kontribusi pemikiran kepada instansi atau unit pengelola bandara dalam upaya peningkatan tingkat pelayanan dalam hal penyediaan tempat parkir kendaraan.
2. Menambah pengalaman, wawasan dan pengetahuan bagi penulis dalam menyusun berbagai bahan dan informasi secara sistematis dalam bentuk karya tulis.
3. Untuk dapat dijadikan bahan pertimbangan untuk penelitian yang berkaitan dimasa yang akan datang.

1.4. POKOK PEMBAHASAN DAN BATASAN MASALAH

1.4.1. Pokok Pembahasan

Adapun pokok-pokok pembahasan dalam penelitian ini meliputi :

1. Jumlah satuan ruang parkir pada tahun 2018 (sebelum pengembangan) dan saat ini (pengembangan tahap 1).
2. Kapasitas ruang parkir kendaraan sesuai pengembangan bandara tahap 1 berdasarkan lama parkir tiap kendaraan.

1.4.2. Batasan Masalah

Adapun batasan masalah dari penelitian ini adalah :

1. Penelitian ini dilaksanakan di Bandar Udara Internasional Sultan Hasanuddin yakni pada tahun 2018 (sebelum pengembangan) dan saat ini (pengembangan tahap 1).

2. Pengamatan langsung dilakukan terhadap kondisi tempat parkir yang ada saat ini, yakni kendaraan yang parkir dan hanya lewat (tidak menggunakan fasilitas parkir).
3. Pengamatan secara langsung dilaksanakan selama jam operasional Bandar Udara Internasional Sultan Hasanuddin (antara jam 00.00 – 24.00 WITA).
4. Pengambilan data sekunder diperoleh melalui kantor pos tollgate keluar masuk Bandar Udara Internasional Sultan Hasanuddin yang meliputi : jam masuk dan keluar kendaraan. Data yang diambil adalah tahun 2018 dikarenakan tahun tersebut merupakan jumlah trafik pertumbuhan paling tinggi, sedangkan pada tahun 2019 mengalami penurunan karena terjadinya kenaikan harga tiket penerbangan yang signifikan.

1.5. SISTEMATIKA PENULISAN

Penulisan tugas akhir ini terdiri dari lima bab, dengan uraian masing-masing bab tersebut untuk memberikan gambaran tentang isi tulisan ini yang disusun secara sistematis sebagai berikut.

1. Bab 1 Pendahuluan

Bab ini membahas tentang latar belakang pemilihan topik penelitian ini, perumusan masalah, tujuan yang ingin dicapai, metodologi penelitian dari sistematika penulisan.

2. Bab 2 Tinjauan Pustaka

Bab ini membahas tentang tinjauan pustaka yang memberikan informasi tentang bahan-bahan yang didapat dari pustaka maupun dari penelitian yang sudah ada.

3. Bab 3 Metode dan Pelaksanaan Penelitian

Bab ini berisikan tentang pelaksanaan penelitian yang meliputi pengumpulan data baik data primer maupun data sekunder serta analisis data yang digunakan.

4. Bab 4 Analisa Data dan Hasil Pembahasan

Bab ini berisikan tentang pengolahan data dan analisa data serta pembahasannya.

5. Bab 5 Kesimpulan dan Saran

Bab ini berisikan tentang kesimpulan dan saran yang diperoleh dari hasil penelitian.

BAB II

TINJAUAN PUSTAKA

Pada tugas akhir ini akan diuraikan beberapa teori yang terkait dengan objek penelitian yang dibuat sebagai berikut:

2.1 PENGERTIAN PARKIR

Kendaraan yang bergerak suatu saat akan berhenti dan pada saat berhenti dibutuhkan tempat untuk memarkir kendaraan tersebut. Parkir merupakan kebutuhan bagi tiap penumpang yang mendatangi suatu lokasi umum maupun komersil seperti mall, gedung perkantoran, hotel, ruko, kampus, bandara, dan lain sebagainya (Nucira, 2007). Dari hubungan ini memperjelas bahwa fasilitas parkir menjadi bagian yang sangat penting dalam sistem transportasi. Oleh karena itu banyak ahli Transportasi yang meneliti dan membuat defenisi tentang parkir yaitu :

- Parkir adalah keadaan tidak bergerak suatu kendaraan yang tidak bersifat sementara (Direktur Jenderal Perhubungan Darat, 1996).
- Parkir adalah tempat pemberhentian kendaraan dalam jangka waktu yang lama atau sebentar tergantung pada kendaraan dan kebutuhannya (Setijowarno & Frazila, 2001).

- Parkir adalah keadaan tidak bergerak suatu kendaraan yang bersifat sementara karena ditinggalkan oleh pengemudinya.



Gambar 2 - 1 Tempat Parkir Kendaraan

Sumber : cermati.com

Tempat-tempat pemberhentian (parkir) kendaraan yang bersifat sementara dan dalam waktu relatif singkat seperti untuk menaikkan dan menurunkan penumpang atau untuk bongkar barang. Tetapi ada juga kendaraan yang berhenti untuk waktu yang relatif lama, misalnya untuk kegiatan belanja, ke kantor, ke sekolah dan kegiatan lainnya, sehingga dibutuhkan tempat parkir bagi kendaraan-kendaraan yang akan berhenti tersebut. Kegiatan parkir dapat dilakukan pada badan jalan dan di area parkir khusus di luar badan jalan.

Dasar peraturan mengenai parkir adalah Keputusan Menteri Perhubungan Nomor: KM 4 Tahun 1994 tentang cara parkir kendaraan bermotor di jalan telah diatur fasilitas parkir untuk umum dan tata cara parkir di jalan, dengan Keputusan Dirjen Darat No. 272/HK.105/DRJD/96.

2.2 JENIS FASILITAS PARKIR

Menurut Direktur Jenderal Perhubungan Darat (1996), fasilitas parkir adalah lokasi yang ditentukan sebagai tempat pemberhentian kendaraan yang tidak bersifat sementara untuk melakukan kegiatan pada suatu kurun waktu. Fasilitas parkir bertujuan untuk memberikan tempat istirahat bagi kendaraan dan untuk menunjang kelancaraan arus lalu lintas. Berdasarkan cara penempatannya dan dalam operasional sehari-hari, sesuai Keputusan Direktur Jenderal Perhubungan Darat No. 272/HK.105/DRJD/96 fasilitas parkir terdiri dari:

2.2.1 Fasilitas Parkir Pada Badan Jalan (*on street parking*)

- a. Pada tepi jalan tanpa pengendalian parkir
- b. Pada kawasan parkir dengan pengendalian parkir



Gambar 2 - 2 Tempat Parkir Pada Badan Jalan

Sumber : tribunnews.com

2.2.2 Fasilitas Parkir Diluar Badan Jalan (*off street parking*)

Fasilitas parkir di luar badan jalan menurut Dirjen Perhubungan Darat (1989), adalah fasilitas parkir kendaraan yang tidak berada pada badan jalan atau langsung menempati pada badan jalan, tetapi berada di luar badan jalan yang dibuat khusus untuk menunjang kegiatan yang dapat berupa taman parkir atau gedung parkir.

Dimana penempatan fasilitas parkir ini terdiri dari:

- a. Fasilitas parkir untuk umum, yaitu tempat yang berupa gedung parkir atau taman parkir untuk umum yang diusahakan sebagai kegiatan tersendiri.



Gambar 2 - 3 Taman Parkir

Sumber : metro.tempo.co

- b. Fasilitas parkir sebagai fasilitas penunjang, yaitu tempat yang berupa gedung parkir yang disediakan untuk menunjang kegiatan pada bangunan utama.



Gambar 2 - 4 Gedung Parkir

Sumber : garasi.id

2.3 KEBUTUHAN TEMPAT PARKIR PADA BANDAR UDARA

Berdasarkan Peraturan Direktur Jenderal Perhubungan Udara Nomor : SKEP/77/VI/2005 Tentang Persyaratan Teknis Pengoperasian Fasilitas Teknik Bandar Udara bahwa tempat parkir disyaratkan sedekat mungkin dengan terminal atau kawasan yang dilayani. Daya tampung parkir dihitung dari jumlah penumpang waktu sibuk. Untuk menghitung kapasitas kendaraan parkir dapat digunakan rumus:

$$\begin{array}{l}
 \mathbf{A = E \times f} \\
 \mathbf{I = A \times h}
 \end{array}
 \dots\dots\dots 2(1)$$

Keterangan :

E = Jumlah penumpang jam sibuk

f = Jumlah kendaraan per penumpang (0,8)

A = Jumlah kendaraan yang parkir

I = Luas lahan parkir

h = Kebutuhan lahan parkir per kendaraan (35 m²)

Tabel 2. 1 Persyaratan Area Luas Parkir

Sumber: SKEP/77/2005

Penumpang waktu sibuk (E)	Jumlah kendaraan parkir (A = E x 0,8)	Luas lahan parkir (I = A x 35 m ²)
≤ 50	≤ 40	≤ 1400
51 – 100	41 – 80	1435 – 2800
101 – 500	81 – 400	2835 – 14000
501 - 1500	40 - 1200	17535 – 42000

2.4 PENENTUAN SATUAN RUANG PARKIR (SRP)

Satuan Ruang Parkir (SRP) adalah ukuran luas efektif untuk meletakkan kendaraan, termasuk ruang bebas dan lebar bukaan pintu (Direktur Jendral Perhubungan Darat, 1998). Satuan Ruang Parkir (SRP) digunakan untuk mengukur kebutuhan ruang parkir.

Di Indonesia, penentuan besar SRP didasarkan pada pertimbangan-pertimbangan berikut ini (Pedoman Perencanaan dan Pengoperasian Fasilitas Parkir, Dirjen Perhubungan Darat, 1998):

2.4.1 Dimensi Kendaraan Standar Untuk Mobil Penumpang

Dimensi kendaraan standar, merupakan ruang batas arah lateral dan memanjang yang diperlukan untuk memarkirkan suatu kendaraan.

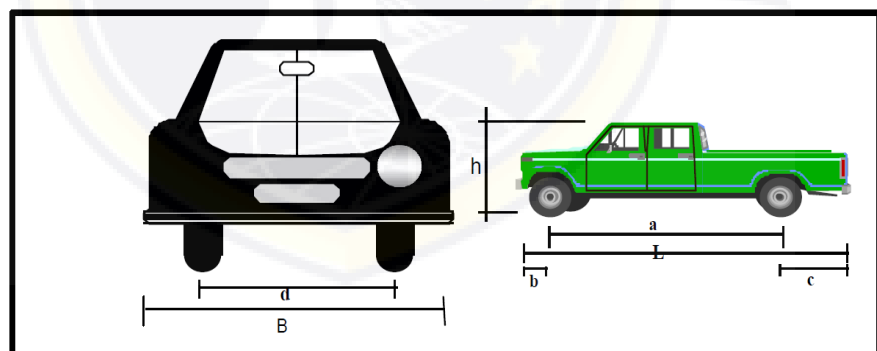

Gambar 2 - 5 Dimensi Kendaraan

a = jarak gandar

d = lebar

b = depan tergantung

h = tinggi total

c = belakang

B = lebar total

tergantung

L = panjang total

2.4.2 Ruang Bebas Kendaraan Parkir

Ruang bebas kendaraan parkir diberikan pada arah lateral dan longitudinal kendaraan. Ruang bebas arah lateral ditetapkan pada saat posisi pintu kendaraan dibuka, yang diukur dari ujung paling luar pintu ke badan kendaraan parkir yang ada disampingnya. Ruang bebas diberikan agar tidak terjadi benturan antara pintu kendaraan dan kendaraan yang parkir disampingnya pada saat penumpang turun dari kendaraan.

Ruang bebas arah memanjang diberikan didepan kendaraan untuk menghindari benturan dengan dinding atau kendaraan yang lewat jalur gang. Jarak bebas arah lateral diambil sebesar 5 cm dan jarak bebas arah longitudinal sebesar 30 cm. Untuk sepeda motor, biasanya ruang bebas arah samping diambil 2 cm dan arah memanjang 20 cm.

2.4.3 Lebar Bukaan Pintu Kendaraan

Ukuran lebar bukaan pintu adalah merupakan fungsi karakteristik pemakai kendaraan yang memanfaatkan fasilitas parkir. Karakteristik pengguna kendaraan yang memanfaatkan fasilitas parkir dibagi menjadi tiga seperti yang ditunjukkan pada Tabel 2.2.

Tabel 2. 2 Lebar Bukaannya Pintu Kendaraan

Jenis Bukaannya Pintu	Pengguna dan/ Peruntukan Fasilitas Parkir	Gol
Pintu depan/belakang terbuka tahap awal 155 cm	<ul style="list-style-type: none"> - Karyawan/pekerja kantor - Tamu/pengunjung pusat kegiatan perkantoran, perdagangan, pemerintahan, universitas 	I
Pintu depan/belakang terbuka penuh 75 cm	<ul style="list-style-type: none"> - Pengunjung tempat olahraga, pusat hiburan/rekreasi, hotel, pusat perdagangan eceran/ swalayan, rumah sakit, bioskop 	II
Pintu depan terbuka penuh dan ditambah untuk pergerakan kursi roda	<ul style="list-style-type: none"> - Orang cacat 	III

Berdasarkan Butir 1 dan 2, penentuan Satuan Ruang Parkir (SRP) dibagi atas tiga jenis kendaraan dan berdasarkan butir 3, penentuan SRP untuk mobil penumpang diklasifikasikan menjadi tiga golongan, seperti pada Tabel 2.3.

Tabel 2. 3 Penentuan Satuan Ruang Parkir (SRP)

Jenis Kendaraan	Satuan Ruang Parkir (m ²)
1. a. Mobil penumpang untuk golongan I	2,30 x 5,00
b. Mobil penumpang untuk golongan II	2,50 x 5,00
c. Mobil penumpang untuk golongan III	3,00 x 5,00
Bus/truk	3,40 x 12,50
Sepeda motor	0,75 x 2,00

Besar satuan ruang parkir untuk tiap jenis kendaraan adalah sebagai berikut.

1) Satuan Ruang Parkir untuk Mobil Penumpang

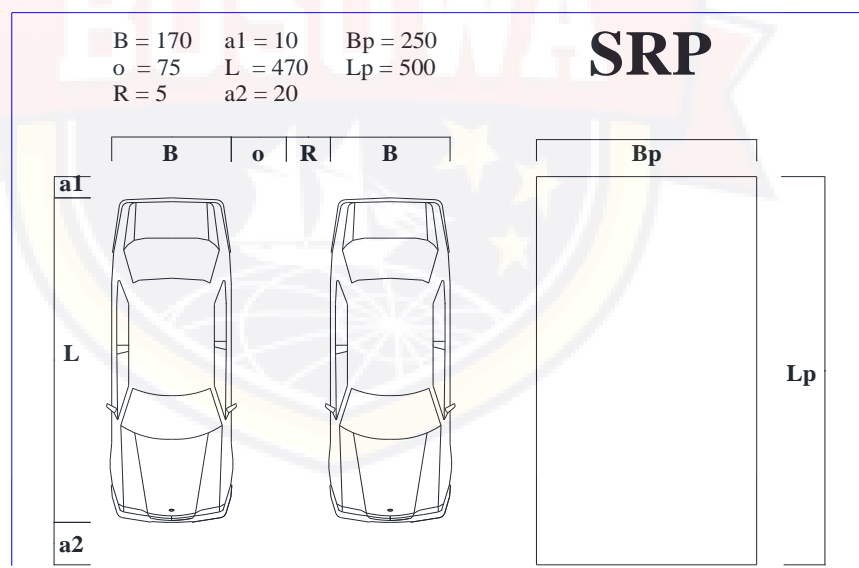

Gambar 2 - 6 Satuan Ruang Parkir (SRP) untuk Mobil Penumpang (dalam cm)

Keterangan :

B = Lebar total kendaraan L = Panjang kendaraan

O = Lebar bukaan pintu A1, a2 = Jarak beba arah

R = Jarak bebas antar lateral Longitudinal

$$\begin{aligned} \text{Gol I : } & B = 170 & a_1 = 10 & B_p = 230 = B + o + R \\ & o = 55 & L = 470 & L_p = 500 = L + a_1 + a_2 \\ & R = 5 & a_2 = 20 & \end{aligned}$$

$$\begin{aligned} \text{Gol II : } & B = 170 & a_1 = 10 & B_p = 250 = B + o + R \\ & o = 75 & L = 470 & L_p = 500 = L + a_1 + a_2 \\ & R = 5 & a_2 = 20 & \end{aligned}$$

$$\begin{aligned} \text{Gol III } & B = 170 & a_1 = 10 & B_p = 300 = B + o + R \\ \vdots & o = 80 & L = 470 & L_p = 500 = L + a_1 + a_2 \\ & R = 5 & a_2 = 20 & \end{aligned}$$

2) Satuan Ruang Parkir untuk Bus/Truk

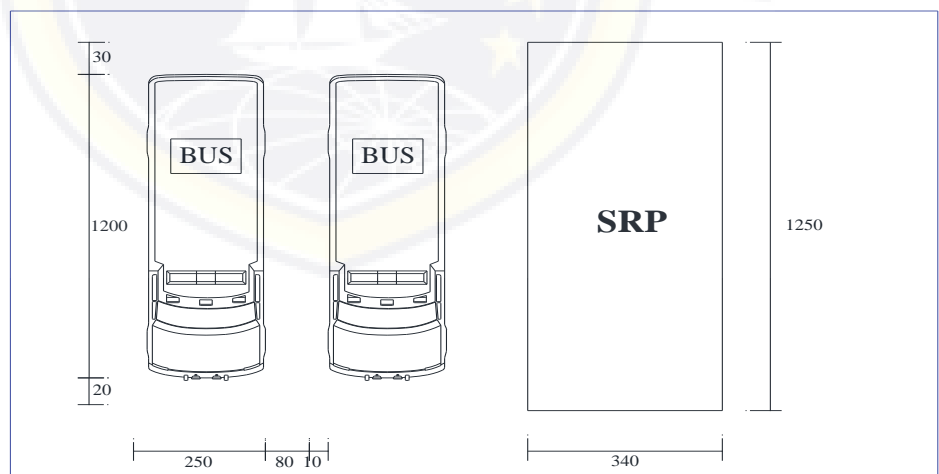

Gambar 2 - 7 Satuan Ruang Parkir (SRP) untuk Bus/Truk

(dalam cm)

3) Satuan Ruang Parkir untuk Sepeda Motor

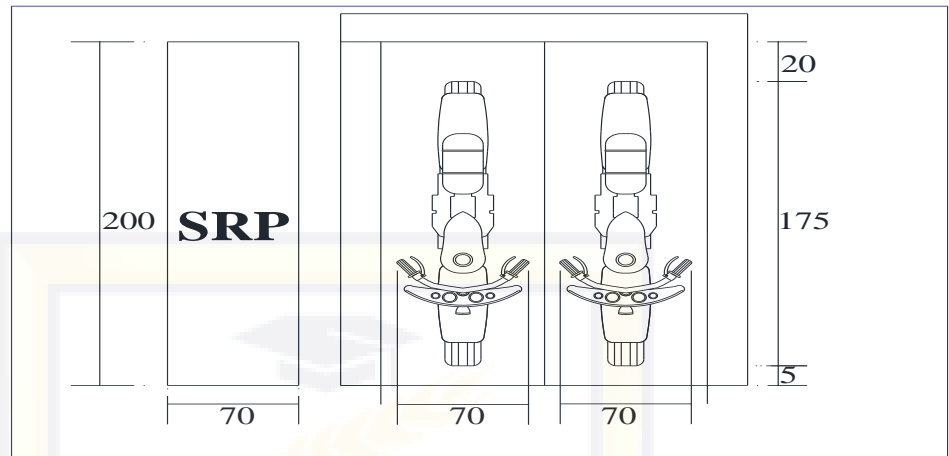

Gambar 2 - 8 Satuan Ruang Parkir (SRP) untuk Sepeda Motor (dalam cm)

2.5 KARAKTERISTIK PARKIR

Data karakteristik parkir akan sangat diperlukan untuk melakukan analisis kondisi operasional dan perancangan pengembangan lahan parkir. Beberapa istilah tentang karakteristik parkir yang harus diketahui agar perencanaan dan pengelolaan parkir dapat dihasilkan dengan baik sesuai fasilitas yang dibutuhkan, diantaranya :

2.5.1 Kapasitas Parkir

Kapasitas parkir adalah jumlah kendaraan maksimum yang dapat dilayani oleh suatu lahan parkir selama waktu pelayanan. Besar kecilnya kapasitas suatu lahan parkir akan sangat menentukan besarnya volume kendaraan yang dapat

ditampung. Hal ini berarti tingkat kapasitas sangat mempengaruhi dimensi lahan parkir tersebut.

2.5.2 Volume Parkir

Volume parkir adalah jumlah keseluruhan kendaraan yang menggunakan fasilitas parkir, biasanya dihitung dalam kendaraan yang parkir dalam satu hari (Abubakar, 1998). Data volume parkir diperlukan untuk mengetahui intensitas penggunaan ruang parkir yang ada di lokasi penelitian. Selain itu juga untuk mengetahui hubungan-hubungan antara jenis kegiatan yang mana banyak membutuhkan ruang parkir.

$$Volume = E_i + X \dots\dots\dots 2(2)$$

Keterangan:

E_i = Jumlah kendaraan yang masuk

X = Kendaraan yang sudah ada sebelum survei

2.5.3 Akumulasi Parkir

Akumulasi parkir adalah jumlah total dari kendaraan yang parkir selama periode tertentu (Hobbs, 1974). Akumulasi ini dapat dijadikan sebagai ukuran kebutuhan ruang parkir di lokasi penelitian. Informasi ini sangat dibutuhkan untuk mengetahui jumlah kendaraan yang sedang berada pada suatu lahan parkir pada selang waktu tertentu. Informasi ini dapat diperoleh dengan cara

menjumlahkan kendaraan yang telah menggunakan lahan parkir ditambah dengan kendaraan yang masuk serta dikurangi dengan kendaraan yang keluar.

$$Akumulasi = E_i - E_x + X \dots\dots\dots 2(3)$$

Keterangan:

E_i = jumlah kendaraan yang masuk lokasi parkir.

E_x = jumlah kendaraan yang keluar lokasi parkir.

X = jumlah kendaraan yang telah berada dilokasi parkir sebelum pengamatan.

2.5.4 Durasi Parkir

Durasi parkir merupakan rentang waktu (lama waktu) kendaraan yang parkir. Lamanya parkir tergantung kepada maksud dan tujuan yang dilakukan. Durasi parkir diperoleh dengan cara mengamati waktu kendaraan masuk dan waktu kendaraan keluar. Selisih dari waktu itu adalah durasi parkir.

$$Durasi = E_{time} - Entime \dots\dots\dots 2(4)$$

Keterangan:

E_{time} = Waktu saat kendaraan keluar lokasi parkir.

$Entime$ = Waktu saat kendaraan masuk lokasi parkir.

2.5.5 Indeks Parkir

Indeks parkir adalah persentase jumlah kendaraan parkir yang menempati area parkir dengan jumlah ruang parkir yang tersedia pada area parkir tersebut. Nilai indeks

parkir ini dapat menunjukkan seberapa kapasitas parkir yang terisi.

$$IP = \frac{\text{Akumulasi}}{\text{Ruang parkir tersedia}} \times 100\% \dots\dots\dots 2(5)$$

2.5.6 Pergantian Parkir (Parking Turnover)

Pergantian parkir atau Parking Turnover menunjukkan tingkat penggunaan ruang parkir yang diperoleh dengan membagi olume parkir dengan jumlah ruang parkir untuk periode waktu tertentu. Rumus yang digunakan untuk menyatakan pergantian parkir adalah sebagai berikut (Oppenlender, 1976):

$$TR = \frac{Nt}{S.Ts} \dots\dots\dots 2(6)$$

Keterangan :

TR : Angka pergantian parkir (kend/SRP/jam)

Nt : Jumlah total kendaraan selama waktu survei (kend)

S : Jumlah petak parkir yang tersedia di lokasi penelitian

Ts : Lama periode analisis/waktu survei (jam)

2.5.7 Akumulasi Parkir Rata-Rata

Akumulasi parkir rata-rata adalah total dari jumlah kendaraan yang parkir disuatu tempat pada waktu tertentu dibagi dengan jumlah jam parkir.

2.5.8 Satuan Ruang Parkir

Satuan ruang parkir adalah ukuran luas efektif untuk meletakkan kendaraan termasuk ruang bebas dan arus lalu lintas dimana dimensi kendaraan dari tahun ketahun cenderung mengecil. Parkir merupakan suatu kebutuhan bagi pemilik kendaraan yang mana pemakai kendaraan menginginkan suatu parkir yang mudah dicapai dan memiliki keamanan yang terjamin.

2.6 DESAIN PARKIR DI LUAR BADAN JALAN

2.6.1 Taman Parkir

Taman parkir adalah suatu areal/bangunan perpajakan yang dilengkapi sarana perparkiran yang pengelolaannya diselenggarakan oleh pemerintah.

2.6.1.1 Kriteria:

- Rencana Umum Tata Ruang Daerah (RUTD)
- Keselamatan dan kelancaran lalu lintas
- Kelestarian lingkungan
- Kemudahan bagi pengguna jasa
- Tersedianya tata guna lahan
- Letak antara jalan akses utama dan daerah yang dilayani

2.6.1.2 Pola Parkir Mobil Penumpang:

1) Parkir kendaraan satu sisi

Pola parkir ini diterapkan apabila ketersediaan ruang sempit.

a) Membentuk sudut 90°

Pola parkir ini mempunyai daya tampung lebih banyak jika dibandingkan dengan pola parkir paralel, tetapi kemudahan dan kenyamanan pengemudi melakukan manuver masuk dan keluar keruangan parkir lebih sedikit jika dibandingkan dengan pola parkir dengan sudut yang lebih kecil dari 90° .

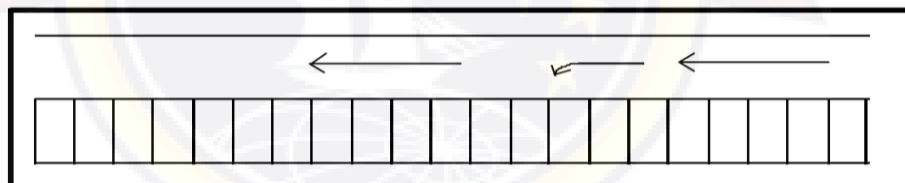

Gambar 2 - 9 Parkir Satu Sisi Dengan Sudut 90°
Sumber: Dirjen Perhubungan Darat

b) Membentuk sudut 30° , 45° , 60°

Pola parkir ini mempunyai daya tampung lebih banyak jika dibandingkan dengan pola parkir paralel, dan kemudahan dan kenyamanan pengemudi melakukan manuver masuk dan keluar

keruangan parkir lebih besar jika dibandingkan dengan pola parkir dengan sudut 90° .

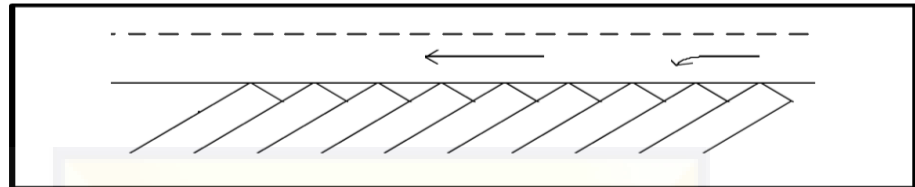

Gambar 2 - 10 Parkir Satu Sisi Dengan Sudut 30° , 45° , 60°
Sumber: Dirjen Perhubungan Darat

2) Parkir kendaraan dua sisi

Pola parkir ini diterapkan apabila ketersediaan ruang cukup memadai.

a) Membentuk sudut 90°

Pada pola parkir ini, arah gerakan lalu lintas kendaraan dapat satu arah atau dua arah.

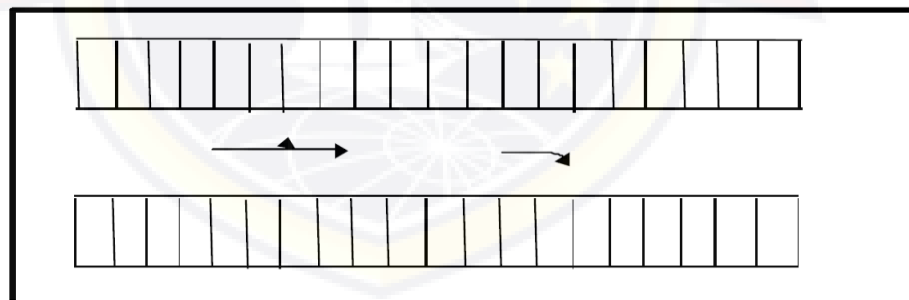

Gambar 2 - 11 Parkir Dua Sisi Dengan Sudut 90°
Sumber: Dirjen Perhubungan Darat

b) Membentuk sudut 30° , 45° , 60°

Pola parkir ini, arah dan gerakan lalu lintas kendaraan dapat satu arah atau dua arah, serta memiliki daya tampung yang

lebih banyak dan memberikan kemudahan pada pengemudi untuk melakukan manuver parkir.

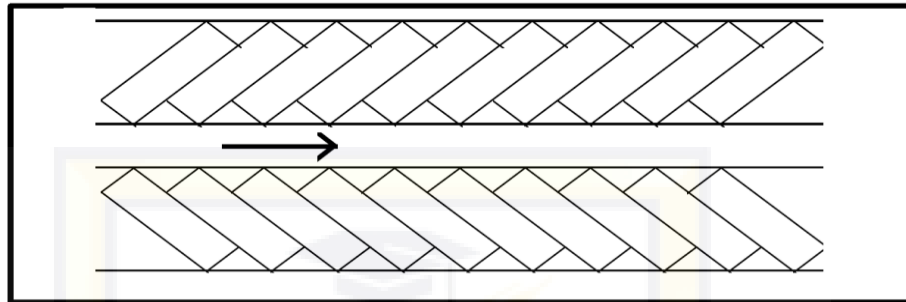

Gambar 2 - 12 Parkir Dua Sisi Dengan Sudut 30° , 45° , 60°
Sumber: Dirjen Perhubungan Darat

3) Pola parkir pulau

Pola parkir ini diterapkan apabila ketersediaan ruang cukup luas.

a) Membentuk sudut 90°

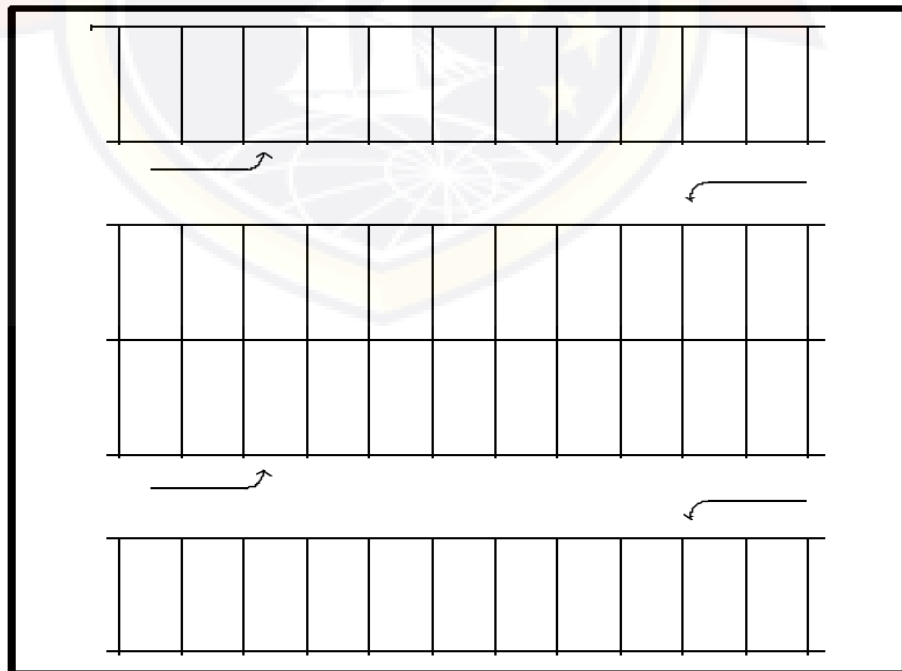

Gambar 2 - 13 Parkir Pulau Dengan Sudut 90°
Sumber: Dirjen Perhubungan Darat

b) Membentuk sudut 45° , dibagi menjadi

1) Bentuk tulang ikan tipe A

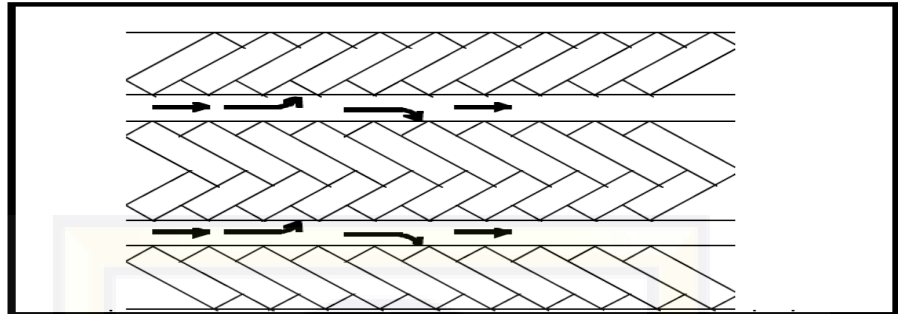

Gambar 2 - 14 Parkir Pulau Dengan Sudut 45° Tipe A
Sumber: Dirjen Perhubungan Darat

2) Bentuk tulang ikan tipe B

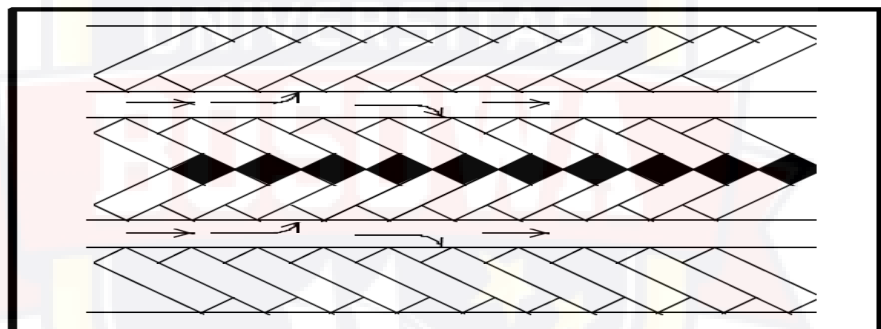

Gambar 2 - 15 Parkir Pulau Dengan Sudut 45° Tipe B
Sumber: Dirjen Perhubungan Darat

3) Bentuk tulang ikan tipe C

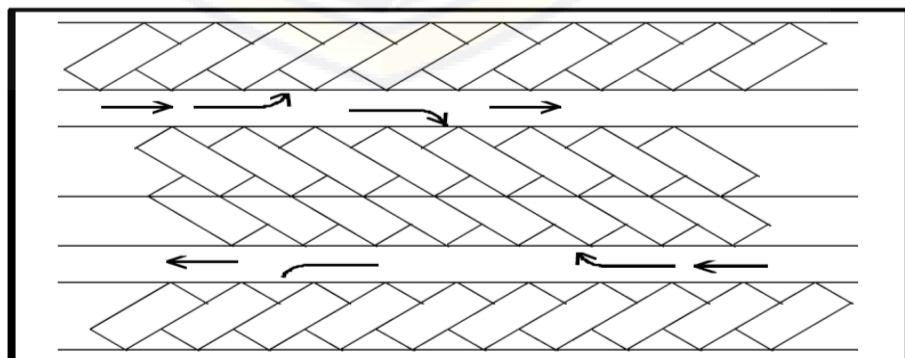

Gambar 2 - 16 Parkir Pulau Dengan Sudut 45° Tipe B
Sumber: Dirjen Perhubungan Darat

2.6.1.3 Pola Parkir Bus/Truk

Posisi kendaraan dapat dibuat menyudut 60° ataupun 90° , tergantung dari luas areal parkir. Dari segi efektivitas ruang, posisi sudut 90° lebih menguntungkan.

1) Pola parkir satu sisi

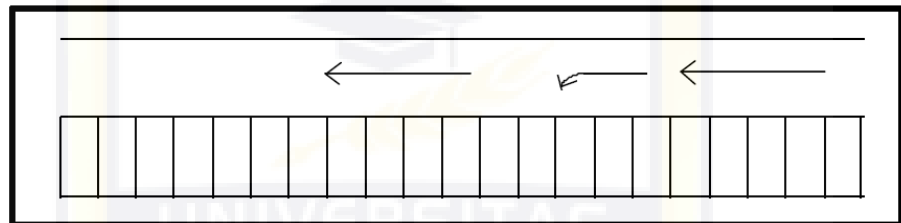

Gambar 2 - 17 Parkir Bus/Truk Satu Sisi
Sumber: Dirjen Perhubungan Darat

2) Pola parkir dua sisi

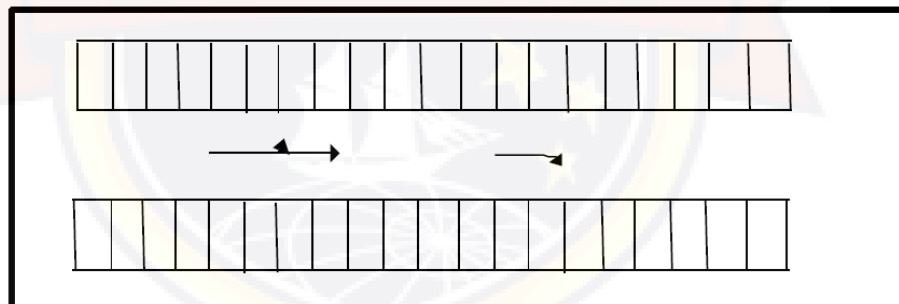

Gambar 2 - 18 Parkir Bus/Truk Satu Sisi
Sumber: Dirjen Perhubungan Darat

2.6.1.4 Pola Parkir Sepeda Motor

Pada umumnya posisi kendaraan adalah 90° . Dari segi efektivitas ruang, posisi sudut 90° paling menguntungkan.

1) Pola parkir satu sisi

Pola ini diterapkan apabila ketersediaan ruang sempit.

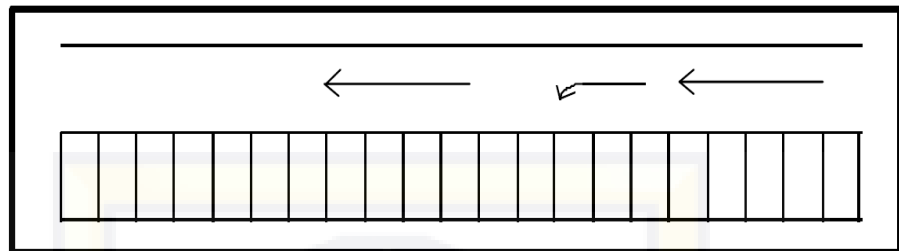

Gambar 2 - 19 Parkir Sepeda Motor Satu Sisi
Sumber: Dirjen Perhubungan Darat

2) Pola parkir dua sisi

Pola ini diterapkan apabila ketersediaan ruang cukup memadai (lebar ruas > 5,6 m).

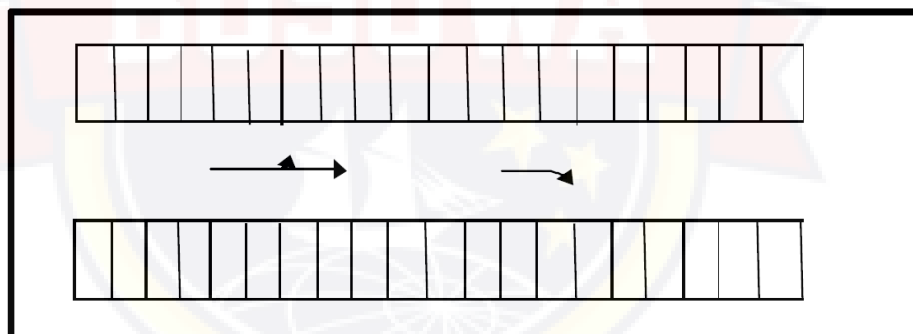

Gambar 2 - 20 Parkir Sepeda Motor Satu Sisi
Sumber: Dirjen Perhubungan Darat

3) Pola parkir pulau

Pola ini diterapkan apabila ketersediaan ruang cukup luas.

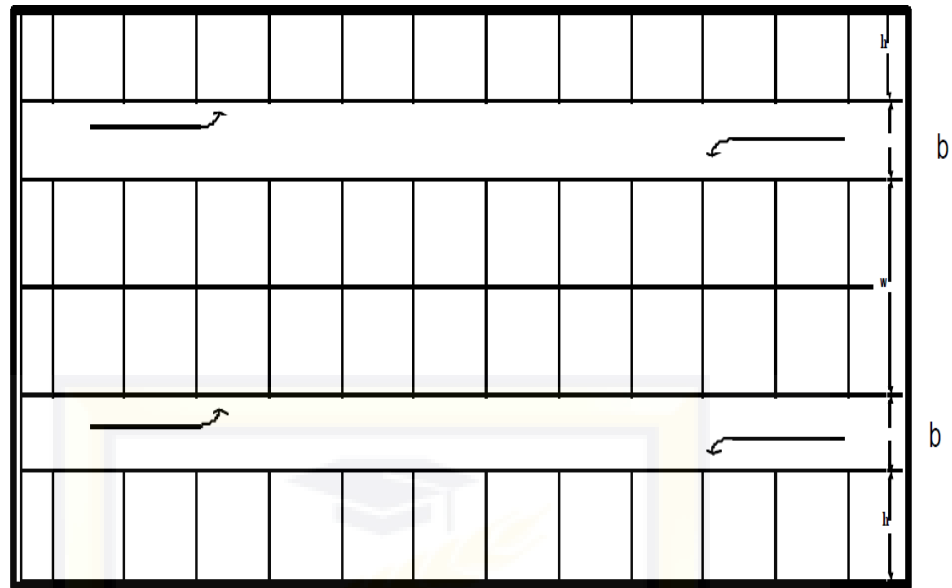

Gambar 2 - 21 Parkir Sepeda Motor Pulau
Sumber: Dirjen Perhubungan Darat

Keterangan:

h = jarak terjauh antara tepi luar satuan ruang parkir

W = lebar terjauh satuan ruang parkir pulau

B = lebar jalur gang

2.6.1.5 Jalur Sirkulasi, Gang, dan Modul

Perbedaan antara jalur sirkulasi dan jalur gang terutama terletak pada penggunaannya. Patokan umum yang dipakai adalah :

- panjang sebuah jalur gang tidak lebih dari 100 meter
- jalur gang yang ini dimaksudkan untuk melayani lebih dari 50 kendaraan dianggap sebagai jalur sirkulasi.

Lebar minimum jalur sirkulasi

- untuk jalan satu arah = 3,5 meter
- untuk jalan dua arah = 6,5 meter

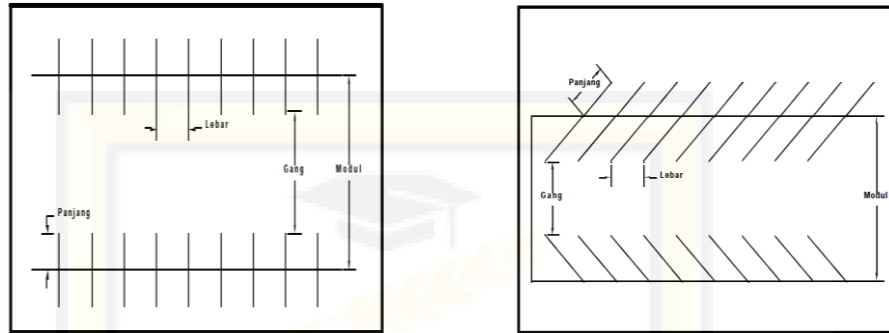

Gambar 2 - 22 Gang dan Modul
Sumber: Dirjen Perhubungan Darat

Tabel 2. 4 Lebar Jalur Gang

SRP	Lebar Jalur Gang (m)							
	< 30°		< 45°		< 60°		< 90°	
	1 arah	2 arah	1 arah	2 arah	1 arah	2 arah	1 arah	2 arah
a. SRP mobil pnp 2,5 m x 5,0 m	3,00*	6,00*	3,00*	6,00*	5,10*	6,00*	6,00*	8,00*
b. SRP mobil pnp 2,5 m x 5,0 m	3,50**	6,50**	3,50**	6,50**	5,10**	6,50**	6,50**	8,00**
c. SRP sepeda motor 0,75 m x 0,3 m	3,00*	6,00*	3,00*	6,00*	4,60*	6,00*	6,00*	1,60*
d. SRP bus / truk 3,4 m x 12,5 m	3,50**	6,50**	3,50**	6,50**	4,60**	6,50**	6,50**	9,50**

Keterangan :

* = lokasi parkir tanpa fasilitas pejalan kaki

** = lokasi parkir dengan fasilitas pejalan kaki

2.6.1.6 Jalan Masuk dan Keluar

Ukuran lebar pintu keluar-masuk dapat ditentukan, yaitu lebar 3 meter dan panjangnya harus dapat menampung tiga mobil berurutan dengan jarak antar mobil (spacing) sekitar 1,5 meter, Oleh karena itu, panjang-lebar pintu keluar masuk minimum 15 meter.

1) Pintu Masuk dan Keluar Terpisah

Satu jalur	Dua jalur
$b = 3,00 - 3,50 \text{ m}$	$b = 6,00 \text{ m}$
$d = 0,80 - 1,00 \text{ m}$	$d = 0,80 - 1,00 \text{ m}$
$R1 = 6,00 - 6,50 \text{ m}$	$R1 = 3,50 - 5,00 \text{ m}$
$R2 = 3,50 - 4,00 \text{ m}$	$R2 = 1,00 - 2,50 \text{ m}$

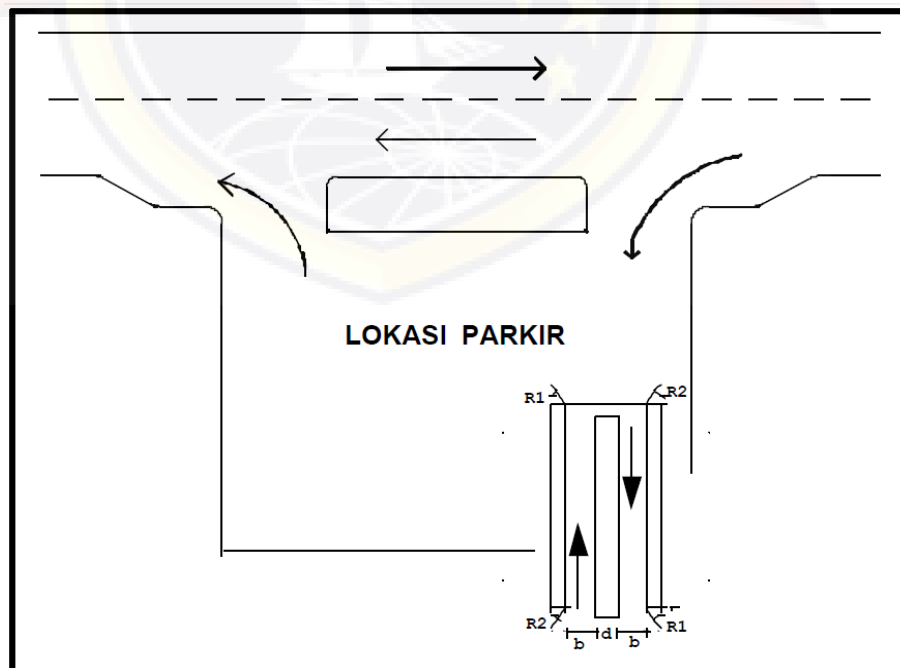

Gambar 2 - 23 Pintu Masuk dan Pintu Keluar Terpisah
Sumber: Dirjen Perhubungan Darat

2) Pintu Masuk dan Keluar Menjadi Satu

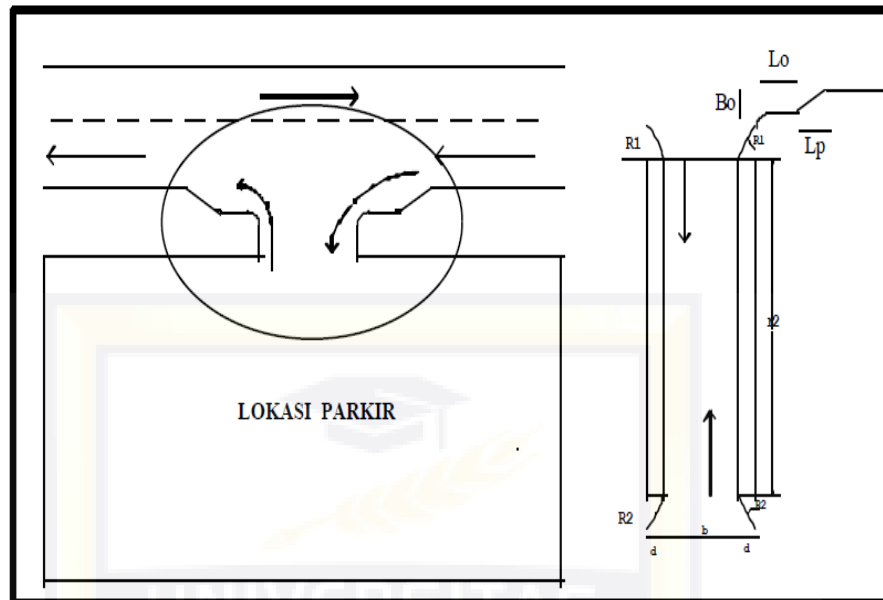

Gambar 2 - 24 Pintu Masuk dan Pintu Keluar Menjadi Satu
Sumber: Dirjen Perhubungan Darat

2.6.1.7 Kriteria Tata Letak Parkir

Tata letak areal parkir kendaraan dapat dibuat bervariasi, bergantung pada ketersediaan bentuk dan ukuran tempat serta jumlah dan letak pintu masuk dan keluar. Tata letak area parkir dapat digolongkan menjadi dua, yaitu sebagai berikut.

1) Tata letak pelataran parkir

Tata letak pelataran parkir dapat diklasifikasikan sebagai berikut.

- a) Pintu masuk dan keluar terpisah dan terletak pada satu ruas jalan.

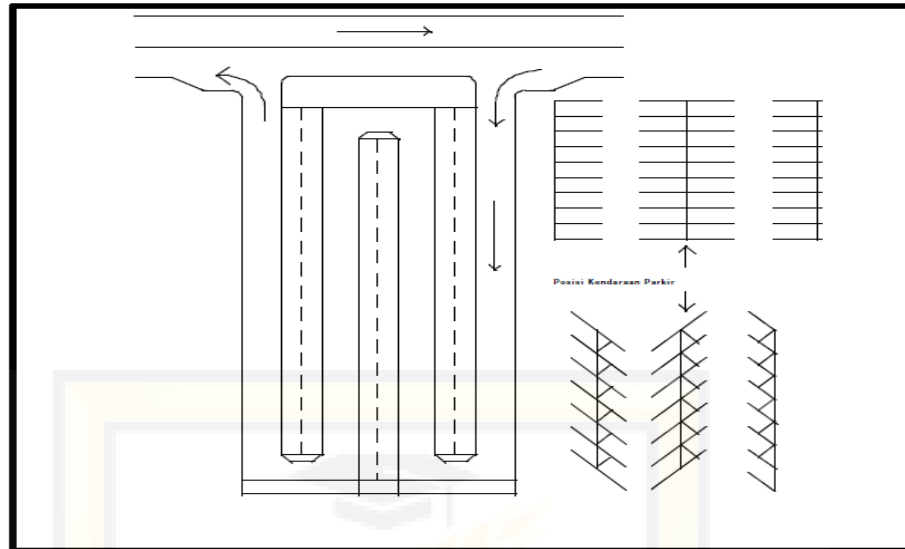

Gambar 2 - 25 Pintu Masuk dan Pintu Keluar Terpisah Pada Satu Ruas Jalan

Sumber: Dirjen Perhubungan Darat

- b) Pintu masuk dan keluar terpisah dan tidak terletak pada satu ruas.
- c) Pintu masuk dan keluar menjadi satu dan terletak pada satu ruas jalan.
- d) Pintu masuk dan keluar yang menjadi satu terletak pada satu ruas berbeda.

BAB III

METODOLOGI PENELITIAN

3.1. METODE PENELITIAN

Jenis penelitian dalam skripsi ini adalah berbentuk penelitian deskriptif kuantitatif. Penelitian deskriptif adalah penelitian yang bertujuan memberikan gambaran yang jelas dan akurat tentang material atau fenomena yang sedang diselidiki. Dikatakan kuantitatif karena penyajian hasil penelitian dengan menggunakan angka - angka statistik. Metode kuantitatif digunakan untuk mengumpulkan data, analisis data, dan interpretasi hasil analisis untuk mendapatkan informasi dalam menarik kesimpulan.

3.2. LOKASI DAN WAKTU PENELITIAN

3.2.1. Gambaran Umum Lokasi Penelitian

Penelitian ini akan dilaksanakan di Bandar Udara Internasional Sultan Hasanuddin. Bandar Udara Internasional Sultan Hasanuddin merupakan bandara kelas I yang terletak di Kabupaten Maros dan Kota Makassar Provinsi Sulawesi Selatan dengan titik referensi Bandar udara/Aerodrome Reference Point (ARP) pada koordinat $05^{\circ} 03' 39,383''$ LS dan $119^{\circ} 33' 16,753''$ BT dengan titik ujung landas pacu I berukuran 2.500 m x 45 m dengan azimuth 13 – 31 dan landas pacu II berukuran 3.100 m x

45 m dengan azimuth 03 – 21. Layout Bandar Udara Internasional Sultan Hasanuddin dapat dilihat pada Gambar 3-1.

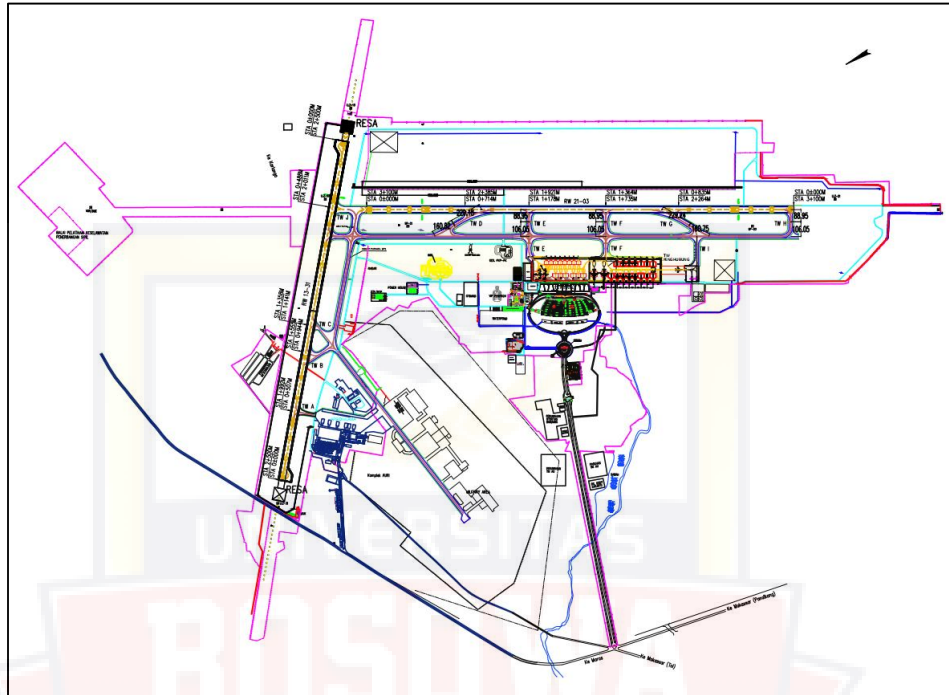

Gambar 3 - 1 Layout Bandara Internasional Sultan Hasanuddin

Sumber : Google

3.2.1. Waktu Penelitian

Waktu Penelitian ini akan dilaksanakan selama 3 hari pada pekan awal Bulan Juli 2022. Adapun jadwal pelaksanaan penelitian dapat dilihat pada tabel 3.1.

Tabel 3. 1 Jadwal Pelaksanaan Penelitian

No	Kegiatan	Juli			
		1	2	3	4
1	Pengambilan Data				
2	Analisis Data				
3	Hasil dan Pembahasan				
4	Ujian Sidang				

3.3. TAHAPAN PENELITIAN

Berdasarkan urutannya, secara garis besar pelaksanaan penelitian ini dapat disusun pada suatu bagan alir yang ditunjukkan pada Gambar 3-2 dan diuraikan dalam beberapa tahap sebagai berikut.

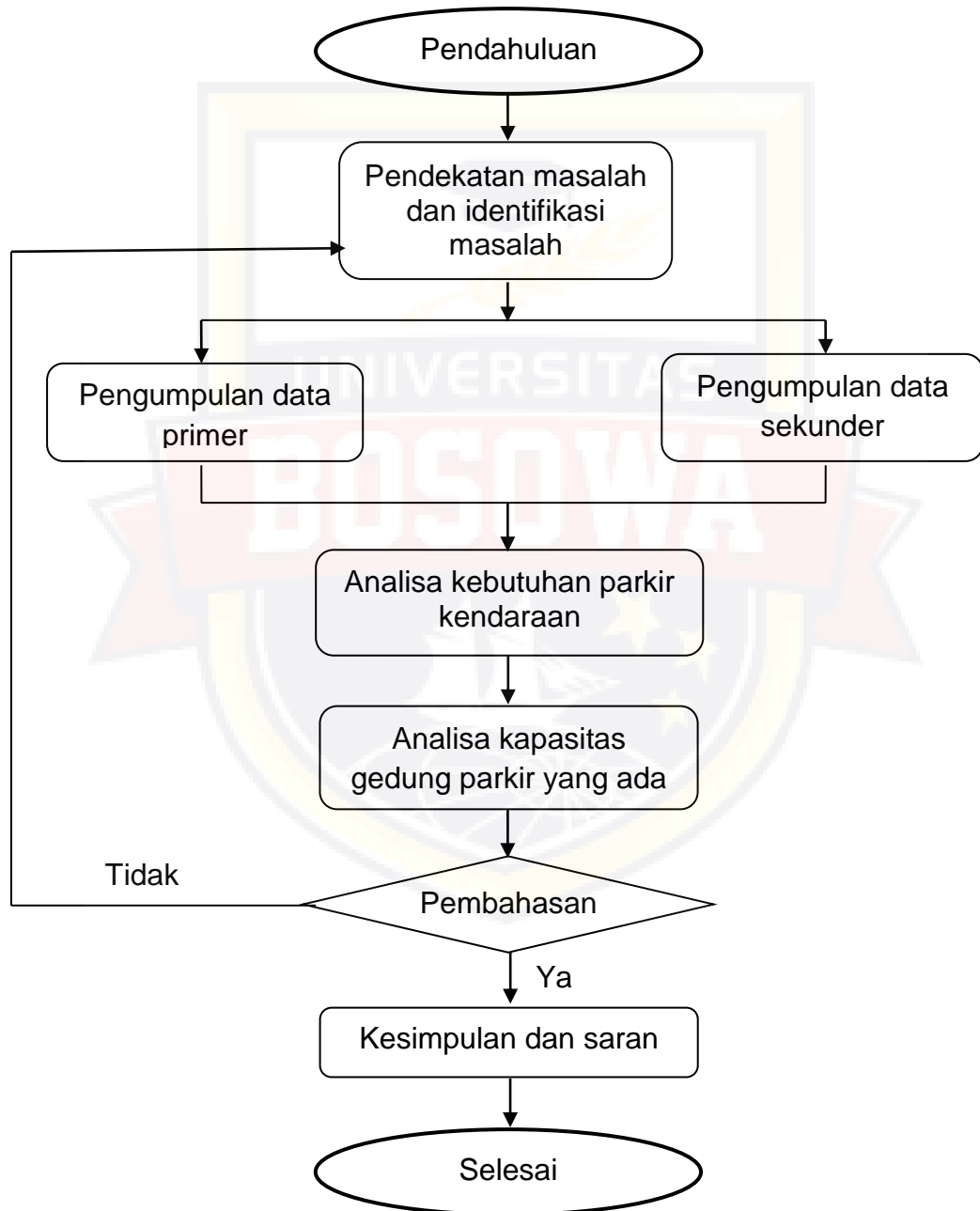

Gambar 3-2 Bagan Alir Penelitian

Berdasarkan Gambar 3-2, tahapan awal dalam penelitian ini yaitu menentukan judul penelitian, identifikasi masalah dan menentukan tujuan penelitian. Pada tahap kedua, dilakukan pengumpulan data yang terdiri data primer dan data sekunder. Data primer merupakan hasil dari observasi terhadap volume kendaraan dan penumpang serta survei melalui penyebaran kuisisioner kepada pengguna terminal yaitu penumpang dan pengemudi angkutan umum. Sedangkan, Data sekunder diperoleh dari pengelola atau instansi terkait yaitu, PT. Angkasa Pura I (Persero).

Tahapan selanjutnya, dilakukan analisis terhadap kinerja operasional terminal berdasarkan data primer dan sekunder yang telah dikumpulkan. Kemudian dilakukan perbandingan terhadap gedung parkir yang sedang dibangun. Setelah itu, dilakukan penarikan kesimpulan berdasarkan hasil analisis dan pembahasan.

3.4. METODE PENGUMPULAN DATA

3.4.1 Teknik Pengumpulan Data

Dalam penulisan ini, ada beberapa teknik pengumpulan data yang digunakan, yaitu:

1. Pengumpulan data primer

Merupakan data yang didapatkan dengan cara survey dan pengamatan langsung ke lapangan. Data primer bisa diperoleh dengan cara:

a. Metode Observasi

Metode pengumpulan data yang dilakukan dengan cara melakukan pengamatan langsung di lapangan, mengenai permasalahan yang ditinjau.

2. Pengumpulan data sekunder

Merupakan data yang diperoleh langsung, tanpa melakukan survey maupun pengamatan langsung. Data sekunder diperoleh dengan cara:

a. Metode Literatur

Metode pengumpulan data yang dilakukan dengan cara mengambil data-data yang diperlukan dari sumber-sumber instansi yang berkaitan, yaitu dari PT. Angkasa Pura I dan PT. Angkasa Pura Support yang mengelola parkir Bandara Internasional Sultan Hasanuddin.

3.5. PEROLEHAN DATA

Tabel 3. 2 Data Pertumbuhan Bandara Sultan Hasanuddin

Tahun 2014 – 2019

Sumber : Data PT. Angkasa Pura I (Persero)

TAHUN	PESAWAT	PENUMPANG	KARGO & POS
2014	83,348	8,828,586	66,873,029
2015	88,549	9,302,437	69,116,043
2016	100,633	10,756,915	72,602,285
2017	113,915	12,294,226	84,549,028
2018	118,543	13,537,770	94,058,617
2019	97,893	10,757,061	65,662,727

BAB IV

HASIL DAN PEMBAHASAN

Berikut merupakan hasil dan pembahasan berdasarkan tujuan penelitian yang tertulis pada bab 1 untuk mengetahui kapasitas yang dikembangkan mampu menampung kendaraan sesuai lama parkir tiap kendaraan.

4.1 DATA LAPANGAN

4.1.1 Data Pertumbuhan Bandara

Data pertumbuhan pesawat, penumpang, kargo dan pos yang dilayani Bandara Internasional Sultan Hasanuddin pada tahun 2014 – 2019 dapat dilihat pada tabel berikut :

Tabel 4. 1 Data Pertumbuhan Bandara Sultan Hasanuddin
Tahun 2014 – 2019

Sumber : Data PT. Angkasa Pura I (Persero)

TAHUN	PESAWAT	PENUMPANG	KARGO & POS
2014	83,348	8,828,586	66,873,029
2015	88,549	9,302,437	69,116,043
2016	100,633	10,756,915	72,602,285
2017	113,915	12,294,226	84,549,028
2018	118,543	13,537,770	94,058,617
2019	97,893	10,757,061	65,662,727

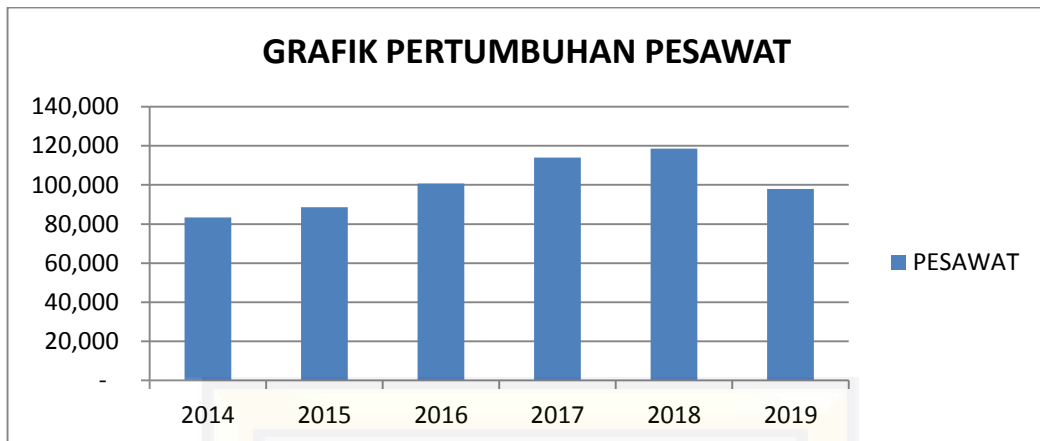

Gambar 4 - 1 Grafik Pertumbuhan Pesawat
Sumber: PT. Angkasa Pura I (Persero)

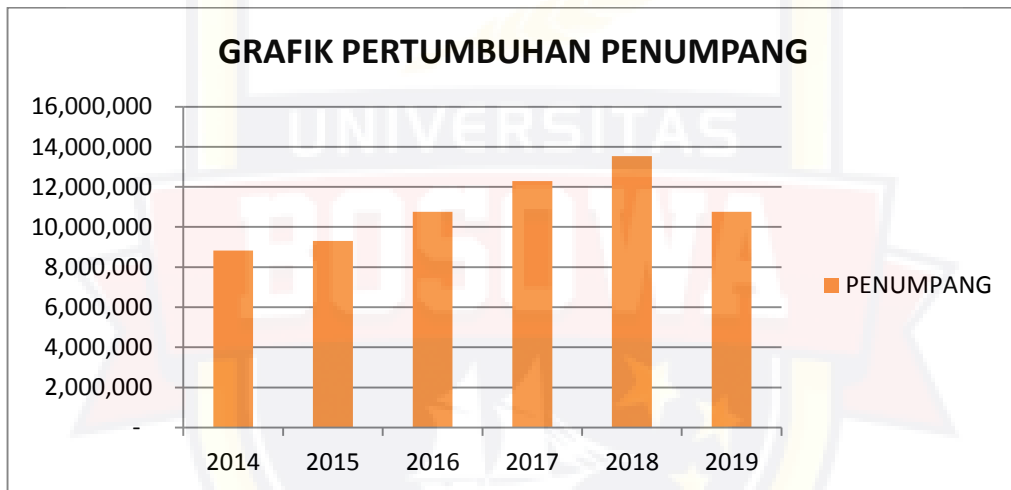

Gambar 4 - 2 Grafik Pertumbuhan Penumpang
Sumber: PT. Angkasa Pura I (Persero)

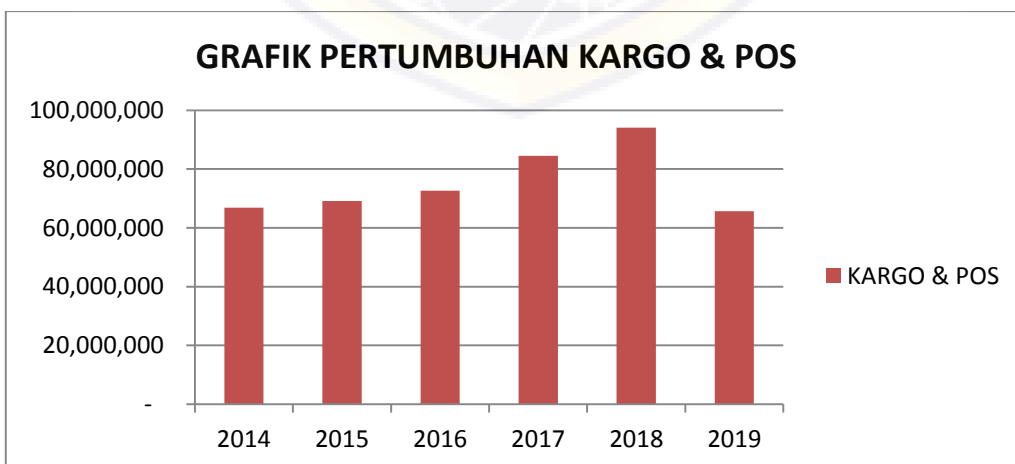

Gambar 4 - 3 Grafik Pertumbuhan Kargo & Pos
Sumber: PT. Angkasa Pura I (Persero)

Berdasarkan grafik diatas sesuai data yang diperoleh dari PT. Angkasa Pura I (Persero) jumlah pergerakan penumpang, pesawat dan kargo di Bandara Internasional Sultan Hasanuddin mengalami peningkatan yang signifikan tiap tahun mulai tahun 2014-2018. Dari grafik tersebut pergerakan pesawat mengalami pertumbuhan sebesar 9,29%, pertumbuhan penumpang sebesar 11,35% serta pertumbuhan kargo dan pos sebesar 9,03%.

Jumlah pergerakan paling tinggi terjadi pada tahun 2018 dengan jumlah pesawat sebanyak 118.543, penumpang sebanyak 13.537.770 dan kargo & pos sebanyak 94.058.617 ton. Akan tetapi pada tahun 2019 terdapat penurunan dibandingkan tahun sebelumnya karena adanya kenaikan harga tiket.

4.1.2 Data Penumpang Jam Sibuk

Penumpang pada jam sibuk sangat mempengaruhi terhadap kebutuhan kapasitas bandara, mulai dari gedung terminal, gedung parkir dan fasilitas lainnya. Sehingga jumlah penumpang pada jam sibuk sangat dibutuhkan dalam menghitung kapasitas fasilitas yang akan disediakan oleh pihak pengelola bandara. Data penumpang jam sibuk di Bandara Internasional Sultan Hasanuddin pada tahun 2018 disampaikan sebagai berikut :

Tabel 4. 2 Data Peak Hour Penumpang Tahun 2018

Sumber : Data PT. Angkasa Pura I (Persero)

PEAK HOUR PENUMPANG DI BANDARA INTERNASIONAL SULTAN HASANUDDIN TAHUN 2018							
BULAN	DOMESTIK			INTERNASIONAL			TOTAL
	KEBERANGKATAN	KEDATANGAN	JUMLAH	KEBERANGKATAN	KEDATANGAN	JUMLAH	
Januari	2514	1757	4271	574	481	1055	5326
Februari	2930	2074	5004	452	428	880	5884
Maret	2683	1905	4588	502	569	1071	5659
April	2573	1972	4545	606	604	1210	5755
Mei	2669	2127	4796	297	864	1161	5957
Juni	2854	2014	4868	173	186	359	5227
Juli	3051	1984	5035	455	177	632	5667
Agustus	3296	1874	5170	600	455	1055	6225
September	2893	2099	4992	174	455	629	5621
Oktober	2853	1836	4689	427	420	847	5536
November	2830	1745	4575	423	423	846	5421
Desember	2266	2121	4387			0	4387
					RATA-RATA		5555.42
					MAKS		6225

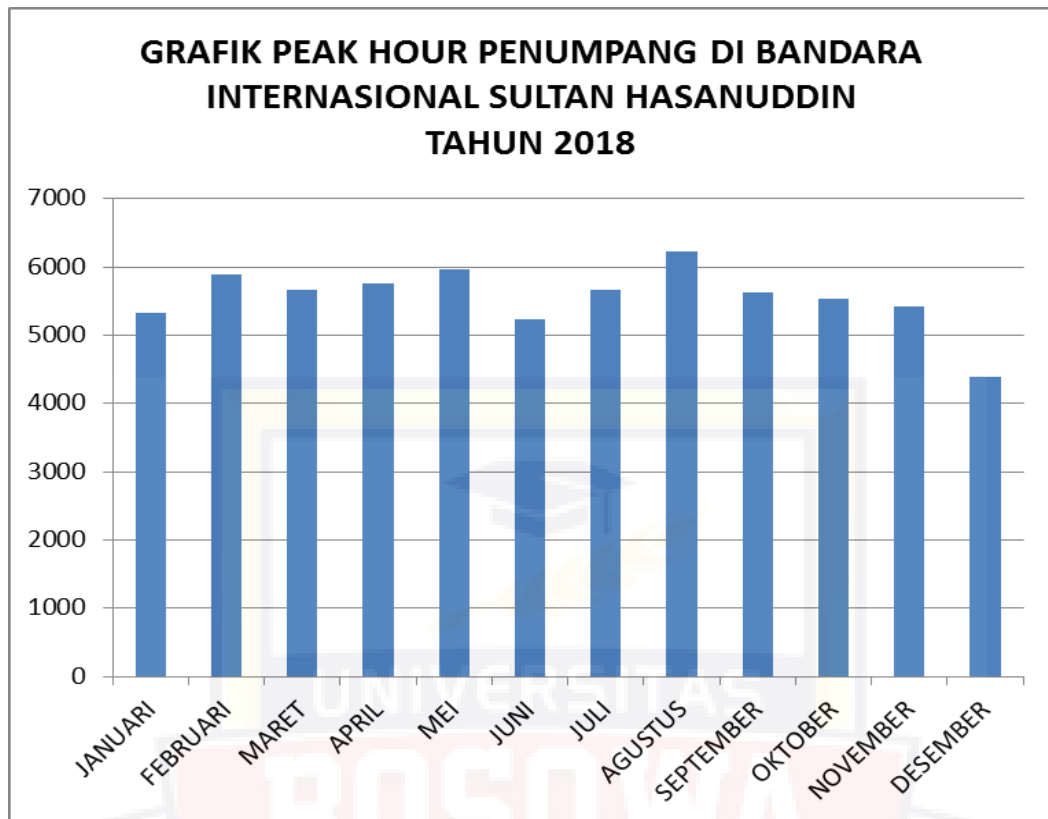

Gambar 4 - 4 Grafik Peak Hour Penumpang Tahun 2018
Sumber: PT. Angkasa Pura I (Persero)

Berdasarkan grafik diatas bahwa penumpang jam sibuk antara bulan januari – desember tahun 2018 tidak mengami trend kenaikan, akan tetapi jumlah perbulannya naik turun. Jumlah penumpang pada jam sibuk paling tinggi untuk kedatangan penumpang domestik sebanyak 3.296 orang pada hari jumat, 31 agustus 2018, untuk keberangkatan penumpang domestik sebanyak 1.874 orang pada hari kamis, 16 agustus 2018, sedangkan kedatangan penumpang internasional sebanyak 600 orang pada hari senin, 13 agustus 2018, untuk keberangkatan penumpang internasional sebanyak 455 orang pada hari rabu, kamis, jumat, 29, 30, 31 agustus 2018.

4.1.3 Data Kendaraan

Pertumbuhan penumpang berbanding sejajar dengan jumlah kendaraan yang beroperasi di bandara. Data jumlah kendaraan sebagai berikut :

Tabel 4. 3 Data Pergerakan Kendaraan Harian Bulan Desember 2018

Sumber : Data PT. Angkasa Pura I (Persero)

TANGGAL	JUMLAH PERGERAKAN KENDARAAN DESEMBER 2018			
	RODA 2	RODA 4	RODA 6 / LEBIH	JUMLAH
1 Des 2018	5,761	12,430	106	18,297
2 Des 2018	6,055	12,151	101	18,307
3 Des 2018	6,367	12,806	106	19,279
4 Des 2018	6,690	12,370	94	19,154
5 Des 2018	6,537	12,971	102	19,610
6 Des 2018	6,815	13,497	104	20,416
7 Des 2018	6,945	14,021	114	21,080
8 Des 2018	6,296	12,375	107	18,778
9 Des 2018	6,005	13,114	98	19,217
10 Des 2018	6,712	13,885	121	20,718
11 Des 2018	6,722	12,691	101	19,514
12 Des 2018	6,664	13,699	94	20,457
13 Des 2018	6,379	13,901	103	20,383
14 Des 2018	6,243	13,689	121	20,053
15 Des 2018	5,894	12,707	113	18,714
16 Des 2018	5,220	14,304	115	19,639
17 Des 2018	6,468	14,255	112	20,835
18 Des 2018	6,498	13,147	96	19,741
19 Des 2018	6,143	14,666	107	20,916
20 Des 2018	7,054	14,935	113	22,102
21 Des 2018	6,497	16,011	123	22,631
22 Des 2018	5,527	15,683	118	21,328
23 Des 2018	6,166	13,648	112	19,926

TANGGAL	JUMLAH PERGERAKAN KENDARAAN DESEMBER 2018			
	RODA 2	RODA 4	RODA 6 / LEBIH	JUMLAH
24 Des 2018	6,090	11,894	91	18,075
25 Des 2018	5,978	11,840	81	17,899
26 Des 2018	5,810	12,296	91	18,197
27 Des 2018	6,215	12,456	112	18,783
28 Des 2018	5,417	12,399	103	17,919
29 Des 2018	5,348	11,745	106	17,199
30 Des 2018	5,635	10,385	102	16,122
31 Des 2018	5,848	8,917	93	14,858
TOTAL	191,999	404,888	3,260	600,147

Tabel 4. 4 Data Pergerakan Kendaraan Harian Bulan Juli 2018

Sumber : Data PT. Angkasa Pura I (Persero)

NO	HARI/TANGGAL	JUMLAH KENDARAAN PARKIR	JUMLAH KENDARAAN TIDAK PARKIR	JUMLAH TOTAL
1	Minggu / 1 Juli 2018	20	80	100
2	Senin / 2 Juli 2018	28	72	100
3	Selasa / 3 Juli 2018	53	47	100
4	Rabu / 4 Juli 2018	22	78	100
5	Kamis / 5 Juli 2018	53	47	100
6	Jumat / 6 Juli 2018	57	43	100
7	Sabtu / 7 Juli 2018	27	73	100
8	Minggu / 8 Juli 2018	53	47	100
9	Senin / 9 Juli 2018	59	41	100
10	Selasa / 10 Juli 2018	29	71	100
	JUMLAH TOTAL	401	599	1,000
	PERSENTASI	40.10%	59.90%	

4.1.4 Data Durasi Parkir

Kebutuhan ruang parkir sangat berpengaruh terhadap lamanya parkir tiap kendaraan (durasi parkir). Data durasi parkir kendaraan yang dilayani Bandara Internasional Sultan Hasanuddin sebagai berikut.

Tabel 4. 5 Durasi Parkir Kendaraan Harian
Sumber : Data PT. Angkasa Pura I (Persero)

Bandar Udara Sultan Hasanuddin

Laporan Transaksi Harian

Tanggal : 01/07/2018 07:00:00 sd 01/07/2018 08:59:59

No	No Nota	Nomor Plat	Kendaraan	Masuk	Keluar	Tarif Masuk	Tarif Keluar	Total	Durasi Parkir
1	22180792064	DD1283KD	MOBIL	01/07/2018 06:32:34	01/07/2018 07:00:58	0	6,000	6,000	0:28:24
2	22180791392	DD1559SP	MOBIL	01/07/2018 01:27:29	01/07/2018 07:01:16	0	35,000	35,000	5:33:47
3	13180553045	DD451XK	MOBIL	01/07/2018 06:51:30	01/07/2018 07:02:14	0	6,000	6,000	0:10:44
4	22180792121	DD388AD	MOBIL	01/07/2018 06:49:39	01/07/2018 07:05:35	0	6,000	6,000	0:15:56
5	12180342007	DD1455VV	MOBIL	01/07/2018 06:38:59	01/07/2018 07:05:50	0	6,000	6,000	0:26:51
6	22180792072	B9370PXR	MOBIL	01/07/2018 06:35:57	01/07/2018 07:06:03	0	6,000	6,000	0:30:06
7	14180778235	DD1397AG	MOBIL	01/07/2018 05:17:49	01/07/2018 07:06:08	0	9,000	9,000	1:48:19

8	22180792125	DD1648RG	MOBIL	01/07/2018 06:51:08	01/07/2018 07:06:31	0	6,000	6,000	0:15:23
9	12180342030	DD1786YH	MOBIL	01/07/2018 06:54:38	01/07/2018 07:06:37	0	6,000	6,000	0:11:59
10	14180778396	DD1060LA	MOBIL	01/07/2018 06:39:26	01/07/2018 07:07:07	0	6,000	6,000	0:27:41
11	14180778247	DD1140HI	MOBIL	01/07/2018 05:22:49	01/07/2018 07:07:27	0	9,000	9,000	1:44:38
12	14180778341	DD1402MH	MOBIL	01/07/2018 06:11:24	01/07/2018 07:09:06	0	6,000	6,000	0:57:42
13	12180342036	DD1652RL	MOBIL	01/07/2018 06:58:54	01/07/2018 07:09:11	0	6,000	6,000	0:10:17
14	14180778456	DD1581UQ	MOBIL	01/07/2018 06:59:35	01/07/2018 07:09:31	0	6,000	6,000	0:09:56
15	22180791968	DD1128KL	MOBIL	01/07/2018 05:41:32	01/07/2018 07:09:51	0	9,000	9,000	1:28:19
16	22180792162	DP7553EZ	MOBIL	01/07/2018 07:00:02	01/07/2018 07:10:05	0	6,000	6,000	0:10:03
17	14180778443	DD164RA	MOBIL	01/07/2018 06:56:16	01/07/2018 07:10:23	0	6,000	6,000	0:14:07
18	14180778463	DD617XY	MOBIL	01/07/2018 07:00:49	01/07/2018 07:11:03	0	6,000	6,000	0:10:14
19	22180791988	DD1206BG	MOBIL	01/07/2018 05:52:11	01/07/2018 07:11:34	0	9,000	9,000	1:19:23
20	22180792116	DD1148SW	MOBIL	01/07/2018 06:48:30	01/07/2018 07:11:44	0	6,000	6,000	0:23:14

Rata-rata Durasi Parkir

0:50:51

Bandar Udara Sultan Hasanuddin
Laporan Transaksi Harian
Tanggal :02/07/2018 07:00:00 sd 02/07/2018 07:59:59

No	No Nota	Nomor Plat	Kendaraan	Masuk	Keluar	Tarif Masuk	Tarif Keluar	Total	Durasi Parkir
1	14180783109	DD999XX	MOBIL	02/07/2018 06:41:59	02/07/2018 07:01:09	0	6,000	6,000	0:19:10
2	13180556272	DD126XY	MOBIL	02/07/2018 06:48:03	02/07/2018 07:01:17	0	6,000	6,000	0:13:14
3	14180783054	DD1856RV	MOBIL	02/07/2018 06:18:23	02/07/2018 07:01:32	0	6,000	6,000	0:43:09
4	12180344155	DD1248XL	MOBIL	02/07/2018 05:06:53	02/07/2018 07:01:33	0	9,000	9,000	1:54:40
5	22180796881	DD805NU	MOBIL	02/07/2018 06:35:26	02/07/2018 07:01:51	0	6,000	6,000	0:26:25
6	22180796896	DD34AF	MOBIL	02/07/2018 06:40:03	02/07/2018 07:01:53	0	6,000	6,000	0:21:50
7	14180781746	DD1643QM	MOBIL	01/07/2018 20:55:26	02/07/2018 07:02:10	0	35,000	35,000	10:06:44
8	22180796822	DA8055RJ	MOBIL	02/07/2018 06:16:29	02/07/2018 07:02:20	0	6,000	6,000	0:45:51
9	22180796911	DD15BR	MOBIL	02/07/2018 06:44:37	02/07/2018 07:02:57	0	6,000	6,000	0:18:20
10	14180783110	DD318	MOBIL	02/07/2018 06:42:18	02/07/2018 07:03:15	0	6,000	6,000	0:20:57
11	14180783121	D866JT	MOBIL	02/07/2018 06:46:27	02/07/2018 07:03:25	0	6,000	6,000	0:16:58
12	22180796921	DD789GL	MOBIL	02/07/2018 06:47:24	02/07/2018 07:03:58	0	6,000	6,000	0:16:34
13	12180344229	DD1231DG	MOBIL	02/07/2018 06:52:44	02/07/2018 07:04:51	0	6,000	6,000	0:12:07

14	14180782969	DD108DA	MOBIL	02/07/2018 05:37:47	02/07/2018 07:05:09	0	9,000	9,000	1:27:22
15	22180796215	DD1281IU	MOBIL	02/07/2018 02:01:07	02/07/2018 07:05:18	0	35,000	35,000	5:04:11
16	14180782798	DD804IU	MOBIL	02/07/2018 04:42:50	02/07/2018 07:05:44	0	12,000	12,000	2:22:54
17	14180783012	DD8924XV	MOBIL	02/07/2018 05:56:35	02/07/2018 07:06:40	0	9,000	9,000	1:10:05
18	13180556228	DD1118KG	MOBIL	02/07/2018 06:17:36	02/07/2018 07:07:28	0	6,000	6,000	0:49:52
19	14180783113	DD1497UV	MOBIL	02/07/2018 06:43:26	02/07/2018 07:08:01	0	6,000	6,000	0:24:35
20	14180782912	DD815MA	MOBIL	02/07/2018 05:17:00	02/07/2018 07:08:07	0	9,000	9,000	1:51:07
21	22180796014	KT1428CO	MOBIL	02/07/2018 00:42:11	02/07/2018 07:08:23	0	35,000	35,000	6:26:12
22	12180344240	DD1608RO	MOBIL	02/07/2018 06:58:20	02/07/2018 07:08:39	0	6,000	6,000	0:10:19
23	14180786476	DD1323HL	MOBIL	02/07/2018 22:08:21	02/07/2018 23:35:00	0	9,000	9,000	1:26:39
24	14180786418	DD110	MOBIL	02/07/2018 21:40:35	02/07/2018 23:35:02	0	9,000	9,000	1:54:27
25	22180800620	DD1301XA	MOBIL	02/07/2018 23:10:30	02/07/2018 23:35:18	0	6,000	6,000	0:24:48
26	14180786647	DD1236DA	MOBIL	02/07/2018 23:23:19	02/07/2018 23:35:24	0	6,000	6,000	0:12:05
27	13180558782	DD1176DR	MOBIL	02/07/2018 22:12:59	02/07/2018 23:35:45	0	9,000	9,000	1:22:46
28	14180786492	DD1923I	MOBIL	02/07/2018 22:15:03	02/07/2018 23:35:57	0	9,000	9,000	1:20:54

Rata-rata Durasi Parkir

1:31:35

Bandar Udara Sultan Hasanuddin

Laporan Transaksi Harian

Tanggal :03/07/2018 07:00:00 sd 03/07/2018 07:59:59

No	No Nota	Nomor Plat	Kendaraan	Masuk	Keluar	Tarif Masuk	Tarif Keluar	Total	Durasi Parkir
1	13180558737	DD1965ON	MOBIL	02/07/2018 21:37:15	03/07/2018 00:00:05	0	12,000	12,000	2:22:50
2	22180800724	D1248UE	MOBIL	02/07/2018 23:49:38	03/07/2018 00:00:05	0	6,000	6,000	0:10:27
3	14180786101	DD1457VO	MOBIL	02/07/2018 19:25:32	03/07/2018 00:00:07	0	19,000	19,000	4:34:35
4	22180800643	DD124AE	MOBIL	02/07/2018 23:20:01	03/07/2018 00:00:27	0	6,000	6,000	0:40:26
5	13180558900	DD8806CF	MOBIL	02/07/2018 23:45:16	03/07/2018 00:00:30	0	6,000	6,000	0:15:14
6	22180800662	DD890XY	MOBIL	02/07/2018 23:29:09	03/07/2018 00:00:33	0	6,000	6,000	0:31:24
7	22180800508	DD477EL	MOBIL	02/07/2018 22:29:32	03/07/2018 00:01:17	0	9,000	9,000	1:31:45
8	22180800660	DD249AE	MOBIL	02/07/2018 23:27:22	03/07/2018 00:01:22	0	6,000	6,000	0:34:00
9	14180786568	DD1492LH	MOBIL	02/07/2018 22:46:05	03/07/2018 00:01:25	0	9,000	9,000	1:15:20
10	14180786630	DD1680QH	MOBIL	02/07/2018 23:13:54	03/07/2018 00:01:30	0	6,000	6,000	0:47:36
11	14180786661	DD1197SI	MOBIL	02/07/2018 23:29:12	03/07/2018 00:01:53	0	6,000	6,000	0:32:41
12	22180800621	DD777XX	MOBIL	02/07/2018 23:10:46	03/07/2018 00:01:54	0	6,000	6,000	0:51:08
13	13180558721	KT1764LW	MOBIL	02/07/2018 21:24:49	03/07/2018 00:02:19	0	12,000	12,000	2:37:30

14	22180800701	DD1969AN	MOBIL	02/07/2018 23:41:30	03/07/2018 00:02:36	0	6,000	6,000	0:21:06
15	13180558823	DD1274RH	MOBIL	02/07/2018 22:45:34	03/07/2018 00:02:53	0	9,000	9,000	1:17:19
16	14180786712	DD1308QQ	MOBIL	02/07/2018 23:49:09	03/07/2018 00:02:56	0	6,000	6,000	0:13:47
17	14180786601	DD1579QD	MOBIL	02/07/2018 23:01:01	03/07/2018 00:03:07	0	9,000	9,000	1:02:06
18	12180346118	DD1105UP	MOBIL	02/07/2018 23:07:55	03/07/2018 00:03:44	0	6,000	6,000	0:55:49
19	12180346137	DD1579RW	MOBIL	02/07/2018 23:45:16	03/07/2018 00:03:57	0	6,000	6,000	0:18:41
20	13180558776	DD1472GE	MOBIL	02/07/2018 22:06:02	03/07/2018 00:04:17	0	9,000	9,000	1:58:15
21	22180800668	B1775SZR	MOBIL	02/07/2018 23:30:29	03/07/2018 00:04:41	0	6,000	6,000	0:34:12
22	22180800642	DD14RR	MOBIL	02/07/2018 23:19:44	03/07/2018 00:04:51	0	6,000	6,000	0:45:07
23	14180786693	DD1063UV	MOBIL	02/07/2018 23:42:20	03/07/2018 00:05:15	0	6,000	6,000	0:22:55
24	22180800537	DD1655RM	MOBIL	02/07/2018 22:38:32	03/07/2018 00:05:15	0	9,000	9,000	1:26:43
25	22180800521	DD73N	MOBIL	02/07/2018 22:33:38	03/07/2018 00:05:46	0	9,000	9,000	1:32:08
26	12180346090	DD1186UC	MOBIL	02/07/2018 22:14:34	03/07/2018 00:05:49	0	9,000	9,000	1:51:15
27	22180800718	DD1063TU	MOBIL	02/07/2018 23:46:38	03/07/2018 00:06:18	0	6,000	6,000	0:19:40
28	22180800738	DD1631RJ	MOBIL	02/07/2018 23:54:59	03/07/2018 00:06:25	0	6,000	6,000	0:11:26
29	22180800689	DD1076KD	MOBIL	02/07/2018 23:37:15	03/07/2018 00:06:41	0	6,000	6,000	0:29:26

30	12180346056	DD1492DI	MOBIL	02/07/2018 21:01:46	03/07/2018 00:06:43	0	15,500	15,500	3:04:57
31	22180800624	DD1158GH	MOBIL	02/07/2018 23:12:14	03/07/2018 00:07:05	0	6,000	6,000	0:54:51
32	14180786640	DD8441MO	MOBIL	02/07/2018 23:19:24	03/07/2018 00:07:31	0	6,000	6,000	0:48:07
33	13180558888	DD1065DF	MOBIL	02/07/2018 23:39:47	03/07/2018 00:07:33	0	6,000	6,000	0:27:46
34	22180800617	DD1439SC	MOBIL	02/07/2018 23:09:47	03/07/2018 00:07:35	0	6,000	6,000	0:57:48
35	22180800571	DD99GQ	MOBIL	02/07/2018 22:51:34	03/07/2018 00:07:56	0	9,000	9,000	1:16:22
36	22180800742	DD415MS	MOBIL	02/07/2018 23:57:06	03/07/2018 00:07:58	0	6,000	6,000	0:10:52
37	14180786258	DD786XY	MOBIL	02/07/2018 20:27:06	03/07/2018 00:08:17	0	15,500	15,500	3:41:11
38	22180799816	DD7260RP	MOBIL	02/07/2018 18:21:45	03/07/2018 00:08:38	0	35,000	35,000	5:46:53
39	14180786673	DD1367TS	MOBIL	02/07/2018 23:34:12	03/07/2018 00:08:54	0	6,000	6,000	0:34:42
40	14180786646	DD118DR	MOBIL	02/07/2018 23:22:46	03/07/2018 00:08:55	0	6,000	6,000	0:46:09
41	13180558882	DD1200RF	MOBIL	02/07/2018 23:34:15	03/07/2018 00:09:17	0	6,000	6,000	0:35:02
42	22180800553	DD1617TQ	MOBIL	02/07/2018 22:43:37	03/07/2018 00:09:34	0	9,000	9,000	1:25:57
43	22180800694	DD1756MU	MOBIL	02/07/2018 23:38:52	03/07/2018 00:09:36	0	6,000	6,000	0:30:44
44	13180558894	DD1139EQ	MOBIL	02/07/2018 23:43:20	03/07/2018 00:10:12	0	6,000	6,000	0:26:52
45	14180786723	DD8654AD	MOBIL	02/07/2018 23:54:10	03/07/2018 00:10:15	0	6,000	6,000	0:16:05

46	14180786484	DD1076HM	MOBIL	02/07/2018 22:13:09	03/07/2018 00:10:19	0	9,000	9,000	1:57:10
47	14180786732	DD867IA	MOBIL	02/07/2018 23:58:59	03/07/2018 00:10:44	0	6,000	6,000	0:11:45
48	13180558886	DD8810TU	MOBIL	02/07/2018 23:38:04	03/07/2018 00:11:05	0	6,000	6,000	0:33:01
49	22180800726	DD1053VC	MOBIL	02/07/2018 23:51:05	03/07/2018 00:11:35	0	6,000	6,000	0:20:30
50	14180786450	DD1004MH	MOBIL	02/07/2018 21:55:41	03/07/2018 00:11:38	0	12,000	12,000	2:15:57
51	14180786579	N1242DG	MOBIL	02/07/2018 22:50:35	03/07/2018 00:12:22	0	9,000	9,000	1:21:47
52	22180800530	DD1961MD	MOBIL	02/07/2018 22:35:48	03/07/2018 00:12:33	0	9,000	9,000	1:36:45
53	14180786653	DP1192CB	MOBIL	02/07/2018 23:25:04	03/07/2018 00:12:39	0	6,000	6,000	0:47:35

Rata-rata Durasi Parkir

1:09:19

Bandar Udara Sultan Hasanuddin

Laporan Transaksi Harian

Tanggal :04/07/2018 07:00:00 sd 04/07/2018 07:59:59

No	No Nota	Nomor Plat	Kendaraan	Masuk	Keluar	Tarif Masuk	Tarif Keluar	Total	Durasi Parkir
1	22180806486	DD1496NS	MOBIL	04/07/2018 06:31:09	04/07/2018 07:00:38	0	6,000	6,000	0:29:29
2	14180791913	DD1756TQ	MOBIL	04/07/2018 05:15:47	04/07/2018 07:01:40	0	9,000	9,000	1:45:53
3	22180806521	DD1292BN	MOBIL	04/07/2018 06:43:16	04/07/2018 07:01:57	0	6,000	6,000	0:18:41

4	13180562548	DD1468K	MOBIL	04/07/2018 06:48:11	04/07/2018 07:02:51	0	6,000	6,000	0:14:40
5	13180562562	DD356AP	MOBIL	04/07/2018 06:52:09	04/07/2018 07:03:15	0	6,000	6,000	0:11:06
6	14180792140	DD1170KO	MOBIL	04/07/2018 06:51:40	04/07/2018 07:03:24	0	6,000	6,000	0:11:44
7	22180806557	DD1197U	MOBIL	04/07/2018 06:52:56	04/07/2018 07:04:27	0	6,000	6,000	0:11:31
8	14180792131	DD1014RT	MOBIL	04/07/2018 06:49:52	04/07/2018 07:04:53	0	6,000	6,000	0:15:01
9	22180806327	DD1827MC	MOBIL	04/07/2018 05:24:22	04/07/2018 07:05:13	0	9,000	9,000	1:40:51
10	14180792152	DD1380EN	MOBIL	04/07/2018 06:54:53	04/07/2018 07:05:55	0	6,000	6,000	0:11:02
11	14180791965	DA8393ZB	MOBIL	04/07/2018 05:32:34	04/07/2018 07:06:51	0	9,000	9,000	1:34:17
12	22180806543	DD1042EP	MOBIL	04/07/2018 06:50:20	04/07/2018 07:06:51	0	6,000	6,000	0:16:31
13	22180806576	566ME	MOBIL	04/07/2018 06:57:29	04/07/2018 07:07:25	0	6,000	6,000	0:09:56
14	13180562576	DD127CC	MOBIL	04/07/2018 06:56:04	04/07/2018 07:07:45	0	6,000	6,000	0:11:41
15	13180562127	DD1367TP	MOBIL	04/07/2018 00:47:00	04/07/2018 07:07:49	0	35,000	35,000	6:20:49
16	14180791964	DD1418KM	MOBIL	04/07/2018 05:32:03	04/07/2018 07:07:50	0	9,000	9,000	1:35:47
17	22180806490	DD66DJ	MOBIL	04/07/2018 06:32:15	04/07/2018 07:08:05	0	6,000	6,000	0:35:50
18	13180562577	DD1177DK	MOBIL	04/07/2018 06:56:16	04/07/2018 07:08:08	0	6,000	6,000	0:11:52
19	13180562574	DW1098AD	MOBIL	04/07/2018 06:55:36	04/07/2018 07:08:41	0	6,000	6,000	0:13:05

20	22180806575	DD1424BN	MOBIL	04/07/2018 06:57:10	04/07/2018 07:09:29	0	6,000	6,000	0:12:19
21	14180792046	DP73G	MOBIL	04/07/2018 06:13:51	04/07/2018 07:10:34	0	6,000	6,000	0:56:43
22	22180806566	DD1663YW	MOBIL	04/07/2018 06:55:04	04/07/2018 07:10:45	0	6,000	6,000	0:15:41

Rata-rata Durasi Parkir

0:49:18

Bandar Udara Sultan Hasanuddin

Laporan Transaksi Harian

Tanggal :05/07/2018 07:00:00 sd 05/07/2018 07:59:59

No	No Nota	Nomor Plat	Kendaraan	Masuk	Keluar	Tarif Masuk	Tarif Keluar	Total	Durasi Parkir
1	14180796080	DD270TB	MOBIL	05/07/2018 00:35:28	05/07/2018 00:46:54	0	6,000	6,000	0:11:26
2	22180810417	DD1905TR	MOBIL	04/07/2018 23:32:11	05/07/2018 00:46:54	0	9,000	9,000	1:14:43
3	22180810458	DD1341RE	MOBIL	04/07/2018 23:48:01	05/07/2018 00:47:14	0	6,000	6,000	0:59:13
4	14180795978	DC34C	MOBIL	04/07/2018 23:52:46	05/07/2018 00:47:30	0	6,000	6,000	0:54:44
5	13180565552	DD1521UK	MOBIL	05/07/2018 00:26:51	05/07/2018 00:47:31	0	6,000	6,000	0:20:40
6	14180796055	DD890XY	MOBIL	05/07/2018 00:25:14	05/07/2018 00:47:46	0	6,000	6,000	0:22:32
7	22180810044	DW1349AO	MOBIL	04/07/2018 21:09:49	05/07/2018 00:47:53	0	15,500	15,500	3:38:04
8	13180565496	DD1471VZ	MOBIL	04/07/2018 23:50:37	05/07/2018 00:48:08	0	6,000	6,000	0:57:31

9	13180565508	DD1486A	MOBIL	04/07/2018 23:58:45	05/07/2018 00:48:27	0	6,000	6,000	0:49:42
10	19180000586	DC1397CV	MOBIL	02/07/2018 05:48:00	05/07/2018 00:48:31	0	240,000	240,000	67:00:31
11	22180810369	DD12KN	MOBIL	04/07/2018 23:13:42	05/07/2018 00:48:37	0	9,000	9,000	1:34:55
12	22180810483	B1928SQO	MOBIL	04/07/2018 23:58:04	05/07/2018 00:49:09	0	6,000	6,000	0:51:05
13	14180795497	DD1320TA	MOBIL	04/07/2018 20:30:21	05/07/2018 00:49:48	0	19,000	19,000	4:19:27
14	13180565413	DD205AH	MOBIL	04/07/2018 22:49:38	05/07/2018 00:50:09	0	12,000	12,000	2:00:31
15	14180795371	DD8941KW	MOBIL	04/07/2018 19:46:19	05/07/2018 00:50:27	0	35,000	35,000	5:04:08
16	13180565414	DD772AD	MOBIL	04/07/2018 22:49:58	05/07/2018 00:50:36	0	12,000	12,000	2:00:38
17	22180810531	DD47KI	MOBIL	05/07/2018 00:17:08	05/07/2018 00:50:54	0	6,000	6,000	0:33:46
18	22180810595	DD1677SN	MOBIL	05/07/2018 00:40:25	05/07/2018 00:51:13	0	6,000	6,000	0:10:48
19	13180565408	DD1367CO	MOBIL	04/07/2018 22:47:58	05/07/2018 00:51:22	0	12,000	12,000	2:03:24
20	13180565564	DD1427XY	MOBIL	05/07/2018 00:33:52	05/07/2018 00:51:31	0	6,000	6,000	0:17:39
21	14180796058	DD458AS	MOBIL	05/07/2018 00:26:05	05/07/2018 00:51:31	0	6,000	6,000	0:25:26
22	13180565521	DD1293OT	MOBIL	05/07/2018 00:08:09	05/07/2018 00:51:48	0	6,000	6,000	0:43:39
23	22180810399	DD1357QP	MOBIL	04/07/2018 23:25:53	05/07/2018 00:51:52	0	9,000	9,000	1:25:59
24	14180795996	B1660KFH	MOBIL	05/07/2018 00:01:07	05/07/2018 00:51:55	0	6,000	6,000	0:50:48

25	14180796007	DD1726SD	MOBIL	05/07/2018 00:05:51	05/07/2018 00:52:05	0	6,000	6,000	0:46:14
26	13180565501	DD1822TQ	MOBIL	04/07/2018 23:55:17	05/07/2018 00:52:20	0	6,000	6,000	0:57:03
27	14180796024	DD39MT	MOBIL	05/07/2018 00:12:53	05/07/2018 00:52:20	0	6,000	6,000	0:39:27
28	13180565575	DD1844SK	MOBIL	05/07/2018 00:43:03	05/07/2018 00:53:06	0	6,000	6,000	0:10:03
29	22180810402	DD1279QK	MOBIL	04/07/2018 23:26:38	05/07/2018 00:53:07	0	9,000	9,000	1:26:29
30	14180796077	DD718XY	MOBIL	05/07/2018 00:34:54	05/07/2018 00:53:14	0	6,000	6,000	0:18:20
31	22180810456	DD1980UQ	MOBIL	04/07/2018 23:46:25	05/07/2018 00:53:42	0	9,000	9,000	1:07:17
32	14180796038	B9159BCT	MOBIL	05/07/2018 00:18:06	05/07/2018 00:53:53	0	6,000	6,000	0:35:47
33	14180796096	DD1247SY	MOBIL	05/07/2018 00:41:28	05/07/2018 00:54:13	0	6,000	6,000	0:12:45
34	14180796025	DD1193LA	MOBIL	05/07/2018 00:13:20	05/07/2018 00:54:30	0	6,000	6,000	0:41:10
35	13180565533	DD1408BL	MOBIL	05/07/2018 00:15:24	05/07/2018 00:54:48	0	6,000	6,000	0:39:24
36	14180795943	PB1530SF	MOBIL	04/07/2018 23:36:23	05/07/2018 00:54:52	0	9,000	9,000	1:18:29
37	22180810467	DD1036BQ	MOBIL	04/07/2018 23:51:09	05/07/2018 00:55:14	0	9,000	9,000	1:04:05
38	13180565503	DD1568SL	MOBIL	04/07/2018 23:55:46	05/07/2018 00:55:22	0	6,000	6,000	0:59:36
39	14180795998	DD1361AI	MOBIL	05/07/2018 00:02:12	05/07/2018 00:55:49	0	6,000	6,000	0:53:37
40	22180810548	DD1349UE	MOBIL	05/07/2018 00:23:06	05/07/2018 00:55:55	0	6,000	6,000	0:32:49

41	22180810275	DW1465LC	MOBIL	04/07/2018 22:41:16	05/07/2018 00:56:17	0	12,000	12,000	2:15:01
42	14180796104	DD1810YU	MOBIL	05/07/2018 00:44:46	05/07/2018 00:56:22	0	6,000	6,000	0:11:36
43	12180350166	DD1122UE	MOBIL	05/07/2018 00:02:32	05/07/2018 00:56:29	0	6,000	6,000	0:53:57
44	14180796084	DD1151ML	MOBIL	05/07/2018 00:37:43	05/07/2018 00:56:36	0	6,000	6,000	0:18:53
45	13180565540	DD1180AY	MOBIL	05/07/2018 00:20:23	05/07/2018 00:56:53	0	6,000	6,000	0:36:30
46	22180810490	DD1476QQ	MOBIL	05/07/2018 00:01:11	05/07/2018 00:57:34	0	6,000	6,000	0:56:23
47	22180810437	DD1343SA	MOBIL	04/07/2018 23:39:24	05/07/2018 00:57:43	0	9,000	9,000	1:18:19
48	22180810427	DD378FA	MOBIL	04/07/2018 23:35:34	05/07/2018 00:58:10	0	9,000	9,000	1:22:36
49	22180810583	DD8324HC	MOBIL	05/07/2018 00:36:19	05/07/2018 00:58:25	0	6,000	6,000	0:22:06
50	22180810455	DD717IK	MOBIL	04/07/2018 23:46:01	05/07/2018 00:58:47	0	9,000	9,000	1:12:46
51	14180796117	DD1570OL	MOBIL	05/07/2018 00:49:01	05/07/2018 00:58:59	0	6,000	6,000	0:09:58
52	22180810529	B7683UDA	MOBIL	05/07/2018 00:15:32	05/07/2018 00:59:16	0	6,000	6,000	0:43:44
53	14180792310	DD887AS	MOBIL	04/07/2018 07:28:18	05/07/2018 00:59:17	0	70,000	70,000	17:30:59

Rata-rata Durasi Parkir

2:37:29

Bandar Udara Sultan Hasanuddin
Laporan Transaksi Harian
Tanggal :06/07/2018 07:00:00 sd 06/07/2018 07:59:59

No	No Nota	Nomor Plat	Kendaraan	Masuk	Keluar	Tarif Masuk	Tarif Keluar	Total	Durasi Parkir
1	22180815954	DD111YA	MOBIL	06/07/2018 04:41:40	06/07/2018 05:00:00	0	6,000	6,000	0:18:20
2	14180801230	DD1007QB	MOBIL	06/07/2018 04:49:12	06/07/2018 05:00:01	0	6,000	6,000	0:10:49
3	13180568927	DD1339ME	MOBIL	06/07/2018 04:42:22	06/07/2018 05:00:04	0	6,000	6,000	0:17:42
4	13180568937	DD1293CG	MOBIL	06/07/2018 04:46:28	06/07/2018 05:00:06	0	6,000	6,000	0:13:38
5	13180568933	DD527ID	MOBIL	06/07/2018 04:44:28	06/07/2018 05:00:16	0	6,000	6,000	0:15:48
6	14180801166	DD1327FD	MOBIL	06/07/2018 04:31:39	06/07/2018 05:00:20	0	6,000	6,000	0:28:41
7	13180568946	DP1020JA	MOBIL	06/07/2018 04:50:02	06/07/2018 05:00:24	0	6,000	6,000	0:10:22
8	22180815982	DD1211NR	MOBIL	06/07/2018 04:49:42	06/07/2018 05:00:33	0	6,000	6,000	0:10:51
9	22180815981	DD1755IZ	MOBIL	06/07/2018 04:49:27	06/07/2018 05:00:38	0	6,000	6,000	0:11:11
10	22180815862	DD1400SI	MOBIL	06/07/2018 04:13:41	06/07/2018 05:00:42	0	6,000	6,000	0:47:01
11	14180801238	D1496AES	MOBIL	06/07/2018 04:50:51	06/07/2018 05:01:01	0	6,000	6,000	0:10:10
12	14180801231	DD1011KQ	MOBIL	06/07/2018 04:49:21	06/07/2018 05:01:08	0	6,000	6,000	0:11:47

13	14180801081	DD1256TS	MOBIL	06/07/2018 03:59:46	06/07/2018 05:01:35	0	9,000	9,000	1:01:49
14	14180801214	DD1340MY	MOBIL	06/07/2018 04:44:32	06/07/2018 05:01:40	0	6,000	6,000	0:17:08
15	13180568952	DD1074MD	MOBIL	06/07/2018 04:51:23	06/07/2018 05:01:55	0	6,000	6,000	0:10:32
16	13180568951	DD79KR	MOBIL	06/07/2018 04:51:02	06/07/2018 05:02:06	0	6,000	6,000	0:11:04
17	12180352561	DD333QP	MOBIL	06/07/2018 04:42:42	06/07/2018 05:02:17	0	6,000	6,000	0:19:35
18	14180801183	DD1078QL	MOBIL	06/07/2018 04:35:55	06/07/2018 05:02:36	0	6,000	6,000	0:26:41
19	14180801227	DD626XK	MOBIL	06/07/2018 04:48:33	06/07/2018 05:02:52	0	6,000	6,000	0:14:19
20	14180801235	DD1645RI	MOBIL	06/07/2018 04:50:19	06/07/2018 05:03:06	0	6,000	6,000	0:12:47
21	22180815991	DD3ST	MOBIL	06/07/2018 04:51:44	06/07/2018 05:03:13	0	6,000	6,000	0:11:29
22	14180801240	DD1707RC	MOBIL	06/07/2018 04:51:19	06/07/2018 05:03:23	0	6,000	6,000	0:12:04
23	22180815957	DD1323SK	MOBIL	06/07/2018 04:42:11	06/07/2018 05:03:30	0	6,000	6,000	0:21:19
24	14180801226	DD1287UV	MOBIL	06/07/2018 04:48:03	06/07/2018 05:03:38	0	6,000	6,000	0:15:35
25	22180815890	DD1524TQ	MOBIL	06/07/2018 04:22:51	06/07/2018 05:03:46	0	6,000	6,000	0:40:55
26	12180352576	DD1550YJ	MOBIL	06/07/2018 04:53:14	06/07/2018 05:04:05	0	6,000	6,000	0:10:51
27	22180815942	DD333QQ	MOBIL	06/07/2018 04:38:56	06/07/2018 05:04:18	0	6,000	6,000	0:25:22
28	22180815999	DD70DK	MOBIL	06/07/2018 04:53:51	06/07/2018 05:04:19	0	6,000	6,000	0:10:28

29	22180815988	DD1190OF	MOBIL	06/07/2018 04:51:01	06/07/2018 05:04:34	0	6,000	6,000	0:13:33
30	12180352578	DD999DP	MOBIL	06/07/2018 04:54:09	06/07/2018 05:04:49	0	6,000	6,000	0:10:40
31	13180568950	DD1115VT	MOBIL	06/07/2018 04:50:48	06/07/2018 05:04:50	0	6,000	6,000	0:14:02
32	13180568958	DDD1742QY	MOBIL	06/07/2018 04:53:52	06/07/2018 05:04:54	0	6,000	6,000	0:11:02
33	14180801246	DD1758RR	MOBIL	06/07/2018 04:53:15	06/07/2018 05:04:56	0	6,000	6,000	0:11:41
34	22180815983	DP789	MOBIL	06/07/2018 04:49:55	06/07/2018 05:05:16	0	6,000	6,000	0:15:21
35	14180801201	DP1244AB	MOBIL	06/07/2018 04:41:26	06/07/2018 05:05:17	0	6,000	6,000	0:23:51
36	14180801234	DD1113XX	MOBIL	06/07/2018 04:50:09	06/07/2018 05:05:32	0	6,000	6,000	0:15:23
37	14180801253	DP459GA	MOBIL	06/07/2018 04:55:06	06/07/2018 05:05:41	0	6,000	6,000	0:10:35
38	14180801007	DD1377MO	MOBIL	06/07/2018 02:59:48	06/07/2018 05:05:42	0	12,000	12,000	2:05:54
39	22180816005	DD1101UG	MOBIL	06/07/2018 04:55:13	06/07/2018 05:05:59	0	6,000	6,000	0:10:46
40	14180801236	DD1030KA	MOBIL	06/07/2018 04:50:30	06/07/2018 05:06:22	0	6,000	6,000	0:15:52
41	22180815823	DD99WZ	MOBIL	06/07/2018 03:56:17	06/07/2018 05:06:24	0	9,000	9,000	1:10:07
42	12180352552	DD8724IC	MOBIL	06/07/2018 04:39:48	06/07/2018 05:06:49	0	6,000	6,000	0:27:01
43	22180815857	DD1522IZ	MOBIL	06/07/2018 04:11:32	06/07/2018 05:06:54	0	6,000	6,000	0:55:22
44	12180352581	DD555UP	MOBIL	06/07/2018 04:56:18	06/07/2018 05:07:13	0	6,000	6,000	0:10:55

45	14180801124	DP1174AZ	MOBIL	06/07/2018 04:16:35	06/07/2018 05:07:16	0	6,000	6,000	0:50:41
46	14180801254	DD202XY	MOBIL	06/07/2018 04:55:19	06/07/2018 05:07:49	0	6,000	6,000	0:12:30
47	14180801244	BK1956IV	MOBIL	06/07/2018 04:52:15	06/07/2018 05:07:57	0	6,000	6,000	0:15:42
48	14180801239	DD1411M	MOBIL	06/07/2018 04:51:04	06/07/2018 05:08:07	0	6,000	6,000	0:17:03
49	22180816017	DD1912RW	MOBIL	06/07/2018 04:58:06	06/07/2018 05:08:09	0	6,000	6,000	0:10:03
50	12180352575	DN378AL	MOBIL	06/07/2018 04:51:54	06/07/2018 05:08:21	0	6,000	6,000	0:16:27
51	13180568835	DD88FR	MOBIL	06/07/2018 03:43:26	06/07/2018 05:08:28	0	9,000	9,000	1:25:02
52	22180815911	DD1073DO	MOBIL	06/07/2018 04:29:51	06/07/2018 05:08:38	0	6,000	6,000	0:38:47
53	22180815985	DD1461XD	MOBIL	06/07/2018 04:50:30	06/07/2018 05:08:45	0	6,000	6,000	0:18:15
54	22180816010	DD1572RB	MOBIL	06/07/2018 04:56:13	06/07/2018 05:08:45	0	6,000	6,000	0:12:32
55	13180568963	DD1281U	MOBIL	06/07/2018 04:56:02	06/07/2018 05:08:54	0	6,000	6,000	0:12:52
56	14180801268	B1310SJT	MOBIL	06/07/2018 04:58:50	06/07/2018 05:09:10	0	6,000	6,000	0:10:20
57	14180801256	DD1262DW	MOBIL	06/07/2018 04:56:00	06/07/2018 05:09:17	0	6,000	6,000	0:13:17

Rata-rata Durasi Parkir

0:22:31

Bandar Udara Sultan Hasanuddin

Laporan Transaksi Harian

Tanggal :07/07/2018 07:00:00 sd 07/07/2018 07:59:59

No	No Nota	Nomor Plat	Kendaraan	Masuk	Keluar	Tarif Masuk	Tarif Keluar	Total	Durasi Parkir
1	22180820827	DD1868YI	MOBIL	07/07/2018 06:24:39	07/07/2018 07:00:39	0	6,000	6,000	0:36:00
2	22180820884	DD1770SN	MOBIL	07/07/2018 06:46:48	07/07/2018 07:01:12	0	6,000	6,000	0:14:24
3	13180572640	DD1276TU	MOBIL	07/07/2018 04:18:19	07/07/2018 07:01:30	0	12,000	12,000	2:43:11
4	22180820776	DD1320LM	MOBIL	07/07/2018 06:00:52	07/07/2018 07:01:42	0	9,000	9,000	1:00:50
5	22180820874	DD143ID	MOBIL	07/07/2018 06:43:42	07/07/2018 07:01:56	0	6,000	6,000	0:18:14
6	13180572818	DD1563TQ	MOBIL	07/07/2018 06:32:26	07/07/2018 07:02:17	0	6,000	6,000	0:29:51
7	22180820871	DD1622QF	MOBIL	07/07/2018 06:42:06	07/07/2018 07:02:22	0	6,000	6,000	0:20:16
8	12180355424	DD1781YH	MOBIL	07/07/2018 06:51:10	07/07/2018 07:03:44	0	6,000	6,000	0:12:34
9	14180806407	DD777XY	MOBIL	07/07/2018 05:06:06	07/07/2018 07:03:46	0	9,000	9,000	1:57:40
10	22180820901	DD1182SS	MOBIL	07/07/2018 06:51:06	07/07/2018 07:03:53	0	6,000	6,000	0:12:47
11	22180820784	DD459CG	MOBIL	07/07/2018 06:06:07	07/07/2018 07:04:29	0	6,000	6,000	0:58:22
12	14180806636	DD1200RF	MOBIL	07/07/2018 06:54:15	07/07/2018 07:05:15	0	6,000	6,000	0:11:00

13	14180806518	DD1915RG	MOBIL	07/07/2018 06:02:14	07/07/2018 07:05:48	0	9,000	9,000	1:03:34
14	13180572360	DD1254YW	MOBIL	06/07/2018 23:55:01	07/07/2018 07:06:53	0	35,000	35,000	7:11:52
15	13180572830	DD1778RS	MOBIL	07/07/2018 06:41:08	07/07/2018 07:07:08	0	6,000	6,000	0:26:00
16	22180820771	B9701PXR	MOBIL	07/07/2018 05:57:46	07/07/2018 07:07:33	0	9,000	9,000	1:09:47
17	22180820924	DD1667SU	MOBIL	07/07/2018 06:56:10	07/07/2018 07:07:57	0	6,000	6,000	0:11:47
18	22180820854	DD1262DW	MOBIL	07/07/2018 06:36:28	07/07/2018 07:08:14	0	6,000	6,000	0:31:46
19	22180820751	DD212XX	MOBIL	07/07/2018 05:45:38	07/07/2018 07:08:23	0	9,000	9,000	1:22:45
20	22180820428	DC1097CY	MOBIL	07/07/2018 03:41:58	07/07/2018 07:08:43	0	15,500	15,500	3:26:45
21	13180572868	DD1652RL	MOBIL	07/07/2018 06:56:15	07/07/2018 07:08:45	0	6,000	6,000	0:12:30
22	22180820919	DD1402IZ	MOBIL	07/07/2018 06:55:12	07/07/2018 07:09:14	0	6,000	6,000	0:14:02
23	14180806649	DD1874QK	MOBIL	07/07/2018 06:58:35	07/07/2018 07:09:16	0	6,000	6,000	0:10:41
24	14180806629	DD1114UC	MOBIL	07/07/2018 06:52:21	07/07/2018 07:09:36	0	6,000	6,000	0:17:15
25	13180572872	DDD1088MO	MOBIL	07/07/2018 06:58:50	07/07/2018 07:09:44	0	6,000	6,000	0:10:54
26	22180820913	DD1265QE	MOBIL	07/07/2018 06:54:06	07/07/2018 07:10:03	0	6,000	6,000	0:15:57
27	14180806652	DD32DD	MOBIL	07/07/2018 06:59:19	07/07/2018 07:10:19	0	6,000	6,000	0:11:00

Rata-rata Durasi Parkir

0:58:13

Bandar Udara Sultan Hasanuddin

Laporan Transaksi Harian

Tanggal :08/07/2018 07:00:00 sd 08/07/2018 07:59:59

No	No Nota	Nomor Plat	Kendaraan	Masuk	Keluar	Tarif Masuk	Tarif Keluar	Total	Durasi Parkir
1	22180824700	DD8675XM	MOBIL	08/07/2018 00:08:54	08/07/2018 00:45:58	0	6,000	6,000	0:37:04
2	14180810368	DD1442QT	MOBIL	08/07/2018 00:31:35	08/07/2018 00:46:05	0	6,000	6,000	0:14:30
3	22180824747	DD1645RI	MOBIL	08/07/2018 00:31:07	08/07/2018 00:46:08	0	6,000	6,000	0:15:01
4	22180824617	DD1332DT	MOBIL	07/07/2018 23:33:44	08/07/2018 00:46:18	0	9,000	9,000	1:12:34
5	13180575437	DD1472AR	MOBIL	07/07/2018 23:50:32	08/07/2018 00:46:24	0	6,000	6,000	0:55:52
6	12180357287	DD21F	MOBIL	07/07/2018 23:31:11	08/07/2018 00:46:33	0	9,000	9,000	1:15:22
7	12180357328	DD1265XS	MOBIL	08/07/2018 00:35:15	08/07/2018 00:46:41	0	6,000	6,000	0:11:26
8	14180810373	B1416BRM	MOBIL	08/07/2018 00:32:55	08/07/2018 00:46:43	0	6,000	6,000	0:13:48
9	14180810221	DT1379BH	MOBIL	07/07/2018 23:28:07	08/07/2018 00:46:45	0	9,000	9,000	1:18:38
10	22180824672	DD1075KL	MOBIL	07/07/2018 23:57:15	08/07/2018 00:46:56	0	6,000	6,000	0:49:41
11	22180824561	DD1860MD	MOBIL	07/07/2018 23:13:23	08/07/2018 00:47:08	0	9,000	9,000	1:33:45

12	13180575461	DD1156TQ	MOBIL	08/07/2018 00:10:10	08/07/2018 00:47:12	0	6,000	6,000	0:37:02
13	14180810366	DD1072LF	MOBIL	08/07/2018 00:30:10	08/07/2018 00:47:17	0	6,000	6,000	0:17:07
14	12180357320	DD1417TW	MOBIL	08/07/2018 00:29:06	08/07/2018 00:47:31	0	6,000	6,000	0:18:25
15	14180810349	DD1094ID	MOBIL	08/07/2018 00:21:44	08/07/2018 00:47:31	0	6,000	6,000	0:25:47
16	14180810382	DD1281QF	MOBIL	08/07/2018 00:36:20	08/07/2018 00:47:31	0	6,000	6,000	0:11:11
17	14180810353	DD407XX	MOBIL	08/07/2018 00:25:17	08/07/2018 00:48:13	0	6,000	6,000	0:22:56
18	14180810243	DD1678TR	MOBIL	07/07/2018 23:37:37	08/07/2018 00:48:22	0	9,000	9,000	1:10:45
19	22180824724	DD1218QI	MOBIL	08/07/2018 00:20:34	08/07/2018 00:48:31	0	6,000	6,000	0:27:57
20	22180824643	DP1143BC	MOBIL	07/07/2018 23:45:25	08/07/2018 00:48:33	0	9,000	9,000	1:03:08
21	22180824737	DD1643A	MOBIL	08/07/2018 00:25:22	08/07/2018 00:48:57	0	6,000	6,000	0:23:35
22	14180810124	DD1314MS	MOBIL	07/07/2018 22:51:27	08/07/2018 00:49:02	0	9,000	9,000	1:57:35
23	22180824576	DD42AT	MOBIL	07/07/2018 23:18:28	08/07/2018 00:49:07	0	9,000	9,000	1:30:39
24	22180824649	DD1733QK	MOBIL	07/07/2018 23:47:00	08/07/2018 00:49:38	0	9,000	9,000	1:02:38
25	22180824609	DD1994YV	MOBIL	07/07/2018 23:30:53	08/07/2018 00:50:01	0	9,000	9,000	1:19:08
26	14180810281	DD1671SY	MOBIL	07/07/2018 23:53:41	08/07/2018 00:50:11	0	6,000	6,000	0:56:30
27	22180824463	DD1294OI	MOBIL	07/07/2018 22:32:37	08/07/2018 00:50:50	0	12,000	12,000	2:18:13

28	13180575487	DD1994IA	MOBIL	08/07/2018 00:30:38	08/07/2018 00:51:49	0	6,000	6,000	0:21:11
29	22180824709	DD1791SH	MOBIL	08/07/2018 00:11:50	08/07/2018 00:51:59	0	6,000	6,000	0:40:09
30	13180575510	DP1146KE	MOBIL	08/07/2018 00:40:44	08/07/2018 00:52:06	0	6,000	6,000	0:11:22
31	12180357304	DD1432IL	MOBIL	08/07/2018 00:01:03	08/07/2018 00:52:15	0	6,000	6,000	0:51:12
32	13180575468	DD364UV	MOBIL	08/07/2018 00:14:52	08/07/2018 00:52:32	0	6,000	6,000	0:37:40
33	14180810339	DD1208RM	MOBIL	08/07/2018 00:17:13	08/07/2018 00:52:56	0	6,000	6,000	0:35:43
34	14180810357	DD277JI	MOBIL	08/07/2018 00:26:49	08/07/2018 00:53:17	0	6,000	6,000	0:26:28
35	12180357279	DP1016BA	MOBIL	07/07/2018 23:16:50	08/07/2018 00:53:31	0	9,000	9,000	1:36:41
36	14180810298	B1387SJI	MOBIL	08/07/2018 00:00:30	08/07/2018 00:53:43	0	6,000	6,000	0:53:13
37	22180824786	DD1685QY	MOBIL	08/07/2018 00:43:29	08/07/2018 00:54:05	0	6,000	6,000	0:10:36
38	13180575506	DD1307MU	MOBIL	08/07/2018 00:39:14	08/07/2018 00:54:08	0	6,000	6,000	0:14:54
39	22180824743	DD1162AH	MOBIL	08/07/2018 00:30:01	08/07/2018 00:54:27	0	6,000	6,000	0:24:26
40	12180357317	DD828DC	MOBIL	08/07/2018 00:20:19	08/07/2018 00:54:54	0	6,000	6,000	0:34:35
41	13180575521	DW1172AC	MOBIL	08/07/2018 00:45:17	08/07/2018 00:54:54	0	6,000	6,000	0:09:37
42	14180810225	DD1278RN	MOBIL	07/07/2018 23:29:02	08/07/2018 00:55:15	0	9,000	9,000	1:26:13
43	22180824435	DP888LT	MOBIL	07/07/2018 22:20:24	08/07/2018 00:56:51	0	12,000	12,000	2:36:27

44	22180824697	DD1734RX	MOBIL	08/07/2018 00:07:34	08/07/2018 00:57:22	0	6,000	6,000	0:49:48
45	14180810059	DP888PB	MOBIL	07/07/2018 22:20:45	08/07/2018 00:57:25	0	12,000	12,000	2:36:40
46	12180357324	DD8926CD	MOBIL	08/07/2018 00:32:47	08/07/2018 00:57:28	0	6,000	6,000	0:24:41
47	14180810405	DD1569RL	MOBIL	08/07/2018 00:44:26	08/07/2018 00:57:44	0	6,000	6,000	0:13:18
48	14180810288	DD1549SM	MOBIL	07/07/2018 23:55:51	08/07/2018 00:57:52	0	9,000	9,000	1:02:01
49	22180824792	DD1773AT	MOBIL	08/07/2018 00:45:10	08/07/2018 00:58:18	0	6,000	6,000	0:13:08
50	14180810362	DD1275IW	MOBIL	08/07/2018 00:28:30	08/07/2018 00:58:54	0	6,000	6,000	0:30:24
51	13180575464	DD1785YI	MOBIL	08/07/2018 00:11:59	08/07/2018 00:59:07	0	6,000	6,000	0:47:08
52	22180824768	DD1016DJ	MOBIL	08/07/2018 00:37:40	08/07/2018 00:59:19	0	6,000	6,000	0:21:39
53	22180824695	DD77RO	MOBIL	08/07/2018 00:06:47	08/07/2018 00:59:28	0	6,000	6,000	0:52:41

Rata-rata Durasi Parkir

0:48:21

Bandar Udara Sultan Hasanuddin

Laporan Transaksi Harian

Tanggal :09/07/2018 07:00:00 sd 09/07/2018 07:59:59

No	No Nota	Nomor Plat	Kendaraan	Masuk	Keluar	Tarif Masuk	Tarif Keluar	Total	Durasi Parkir
1	14180815220	DW1770BN	MOBIL	09/07/2018 00:34:21	09/07/2018 00:48:34	0	6,000	6,000	0:14:13

2	13180578842	DD1127QF	MOBIL	09/07/2018 00:35:22	09/07/2018 00:48:39	0	6,000	6,000	0:13:17
3	13180578697	F1470EY	MOBIL	08/07/2018 23:04:32	09/07/2018 00:48:53	0	9,000	9,000	1:44:21
4	22180829667	DW1286QA	MOBIL	09/07/2018 00:38:34	09/07/2018 00:48:55	0	6,000	6,000	0:10:21
5	14180801315	DD1270YV	MOBIL	06/07/2018 05:11:38	09/07/2018 00:48:56	0	210,000	210,000	67:37:18
6	13180578850	B1212ART	MOBIL	09/07/2018 00:38:48	09/07/2018 00:49:09	0	6,000	6,000	0:10:21
7	14180815141	DD1158SV	MOBIL	09/07/2018 00:05:27	09/07/2018 00:49:10	0	6,000	6,000	0:43:43
8	22180829582	AG600AW	MOBIL	09/07/2018 00:09:17	09/07/2018 00:49:26	0	6,000	6,000	0:40:09
9	12180359737	DD1476DR	MOBIL	09/07/2018 00:36:40	09/07/2018 00:49:32	0	6,000	6,000	0:12:52
10	12180359626	DD1152DK	MOBIL	08/07/2018 21:55:57	09/07/2018 00:49:37	0	12,000	12,000	2:53:40
11	14180815098	DD1325HZ	MOBIL	08/07/2018 23:49:35	09/07/2018 00:49:50	0	9,000	9,000	1:00:15
12	22180829648	DP1075GK	MOBIL	09/07/2018 00:33:25	09/07/2018 00:49:50	0	6,000	6,000	0:16:25
13	22180829634	DD1353BE	MOBIL	09/07/2018 00:29:24	09/07/2018 00:50:00	0	6,000	6,000	0:20:36
14	14180815175	DD1976RS	MOBIL	09/07/2018 00:20:16	09/07/2018 00:50:08	0	6,000	6,000	0:29:52
15	14180815236	DD1422RH	MOBIL	09/07/2018 00:39:04	09/07/2018 00:50:17	0	6,000	6,000	0:11:13
16	22180829366	DD1659RQ	MOBIL	08/07/2018 22:50:42	09/07/2018 00:50:25	0	9,000	9,000	1:59:43
17	13180578802	DD1846RB	MOBIL	09/07/2018 00:06:07	09/07/2018 00:50:30	0	6,000	6,000	0:44:23

18	22180829668	DD1148RH	MOBIL	09/07/2018 00:38:49	09/07/2018 00:50:32	0	6,000	6,000	0:11:43
19	14180815094	DD1641RA	MOBIL	08/07/2018 23:48:18	09/07/2018 00:50:44	0	9,000	9,000	1:02:26
20	14180814871	DW1411CB	MOBIL	08/07/2018 22:21:31	09/07/2018 00:50:48	0	12,000	12,000	2:29:17
21	22180829632	DD1836KF	MOBIL	09/07/2018 00:28:43	09/07/2018 00:50:49	0	6,000	6,000	0:22:06
22	13180578763	DD1492XR	MOBIL	08/07/2018 23:43:59	09/07/2018 00:51:00	0	9,000	9,000	1:07:01
23	12180359740	DD1607SN	MOBIL	09/07/2018 00:40:47	09/07/2018 00:51:07	0	6,000	6,000	0:10:20
24	22180829547	DD1371QG	MOBIL	08/07/2018 23:57:31	09/07/2018 00:51:13	0	6,000	6,000	0:53:42
25	14180815240	DW1412BE	MOBIL	09/07/2018 00:39:57	09/07/2018 00:51:18	0	6,000	6,000	0:11:21
26	14180815131	DD1427SU	MOBIL	09/07/2018 00:02:11	09/07/2018 00:51:32	0	6,000	6,000	0:49:21
27	14180815090	DD1299MG	MOBIL	08/07/2018 23:46:50	09/07/2018 00:51:42	0	9,000	9,000	1:04:52
28	14180815022	DD1153UJ	MOBIL	08/07/2018 23:21:55	09/07/2018 00:51:53	0	9,000	9,000	1:29:58
29	12180359716	DD1856RZ	MOBIL	09/07/2018 00:21:21	09/07/2018 00:52:12	0	6,000	6,000	0:30:51
30	22180829663	DD1151EG	MOBIL	09/07/2018 00:37:27	09/07/2018 00:52:22	0	6,000	6,000	0:14:55
31	22180829565	DD1141TW	MOBIL	09/07/2018 00:03:38	09/07/2018 00:52:25	0	6,000	6,000	0:48:47
32	14180815151	DD8748XH	MOBIL	09/07/2018 00:09:02	09/07/2018 00:52:28	0	6,000	6,000	0:43:26
33	22180829453	DD1256MV	MOBIL	08/07/2018 23:24:52	09/07/2018 00:52:34	0	9,000	9,000	1:27:42

34	14180815242	DD1093ME	MOBIL	09/07/2018 00:40:35	09/07/2018 00:52:44	0	6,000	6,000	0:12:09
35	14180814836	DD722BK	MOBIL	08/07/2018 22:06:22	09/07/2018 00:52:46	0	12,000	12,000	2:46:24
36	13180578726	DD554VA	MOBIL	08/07/2018 23:22:24	09/07/2018 00:52:59	0	9,000	9,000	1:30:35
37	22180829527	DD1178UJ	MOBIL	08/07/2018 23:49:48	09/07/2018 00:53:13	0	9,000	9,000	1:03:25
38	22180829469	DD1371VK	MOBIL	08/07/2018 23:29:53	09/07/2018 00:53:14	0	9,000	9,000	1:23:21
39	14180815020	DD1582RY	MOBIL	08/07/2018 23:19:55	09/07/2018 00:53:17	0	9,000	9,000	1:33:22
40	22180829228	DP112DA	MOBIL	08/07/2018 21:58:18	09/07/2018 00:53:39	0	12,000	12,000	2:55:21
41	13180578813	DD1684TQ	MOBIL	09/07/2018 00:19:01	09/07/2018 00:54:00	0	6,000	6,000	0:34:59
42	14180815212	DD304AI	MOBIL	09/07/2018 00:32:33	09/07/2018 00:54:36	0	6,000	6,000	0:22:03
43	13180578839	DD1206AT	MOBIL	09/07/2018 00:33:14	09/07/2018 00:54:58	0	6,000	6,000	0:21:44
44	13180578695	DW53C	MOBIL	08/07/2018 23:00:29	09/07/2018 00:55:11	0	9,000	9,000	1:54:42
45	13180578688	DD2686AY	MOBIL	08/07/2018 22:54:05	09/07/2018 00:55:23	0	12,000	12,000	2:01:18
46	22180829646	DD8852MR	MOBIL	09/07/2018 00:32:41	09/07/2018 00:55:30	0	6,000	6,000	0:22:49
47	13180578823	B1947UIR	MOBIL	09/07/2018 00:26:05	09/07/2018 00:55:51	0	6,000	6,000	0:29:46
48	12180359657	DD8154XY	MOBIL	08/07/2018 22:49:00	09/07/2018 00:55:57	0	12,000	12,000	2:06:57
49	14180815104	DD1273DW	MOBIL	08/07/2018 23:51:57	09/07/2018 00:56:08	0	9,000	9,000	1:04:11

50	14180815113	DD1704TS	MOBIL	08/07/2018 23:54:42	09/07/2018 00:56:26	0	9,000	9,000	1:01:44
51	14180815190	DD1356VM	MOBIL	09/07/2018 00:26:09	09/07/2018 00:56:32	0	6,000	6,000	0:30:23
52	14180814770	DD1141CB	MOBIL	08/07/2018 21:39:06	09/07/2018 00:56:50	0	15,500	15,500	3:17:44
53	14180815162	DD1707SI	MOBIL	09/07/2018 00:14:00	09/07/2018 00:56:54	0	6,000	6,000	0:42:54
54	14180815243	DD1277SP	MOBIL	09/07/2018 00:40:45	09/07/2018 00:56:54	0	6,000	6,000	0:16:09
55	22180829572	B2119SZM	MOBIL	09/07/2018 00:06:04	09/07/2018 00:57:16	0	6,000	6,000	0:51:12
56	13180578840	DD1188PW	MOBIL	09/07/2018 00:33:43	09/07/2018 00:57:20	0	6,000	6,000	0:23:37
57	13180578756	DD1528QH	MOBIL	08/07/2018 23:38:31	09/07/2018 00:57:24	0	9,000	9,000	1:18:53
58	14180814303	DD1134DN	MOBIL	08/07/2018 18:45:08	09/07/2018 00:57:38	0	35,000	35,000	6:12:30
59	13180578853	DT1514AK	MOBIL	09/07/2018 00:40:56	09/07/2018 00:58:02	0	6,000	6,000	0:17:06

Rata-rata Durasi Parkir

2:11:07

Bandar Udara Sultan Hasanuddin

Laporan Transaksi Harian

Tanggal :10/07/2018 07:00:00 sd 10/07/2018 07:59:59

No	No Nota	Nomor Plat	Kendaraan	Masuk	Keluar	Tarif Masuk	Tarif Keluar	Total	Durasi Parkir
1	14180820793	DD777XX	MOBIL	10/07/2018 06:51:00	10/07/2018 07:01:00	0	6,000	6,000	0:10:00

2	22180835387	DD44LO	MOBIL	10/07/2018 05:37:28	10/07/2018 07:01:00	0	9,000	9,000	1:23:32
3	22180835559	DC1247BG	MOBIL	10/07/2018 06:47:07	10/07/2018 07:01:33	0	6,000	6,000	0:14:26
4	13180582455	DD1837TQ	MOBIL	10/07/2018 06:27:29	10/07/2018 07:01:34	0	6,000	6,000	0:34:05
5	22180835560	DD1524YJ	MOBIL	10/07/2018 06:47:27	10/07/2018 07:01:57	0	6,000	6,000	0:14:30
6	14180820730	B70GIL	MOBIL	10/07/2018 06:29:22	10/07/2018 07:02:02	0	6,000	6,000	0:32:40
7	14180820801	DD754AL	MOBIL	10/07/2018 06:52:31	10/07/2018 07:02:35	0	6,000	6,000	0:10:04
8	22180835417	DD1422BD	MOBIL	10/07/2018 05:50:12	10/07/2018 07:03:13	0	9,000	9,000	1:13:01
9	22180835359	DD1420RY	MOBIL	10/07/2018 05:24:15	10/07/2018 07:03:44	0	9,000	9,000	1:39:29
10	14180820726	DD1305DV	MOBIL	10/07/2018 06:27:58	10/07/2018 07:04:08	0	6,000	6,000	0:36:10
11	13180582459	DD1909YH	MOBIL	10/07/2018 06:29:30	10/07/2018 07:04:22	0	6,000	6,000	0:34:52
12	22180835583	B7189II	MOBIL	10/07/2018 06:54:41	10/07/2018 07:05:16	0	6,000	6,000	0:10:35
13	13180582506	DD1162AH	MOBIL	10/07/2018 06:54:24	10/07/2018 07:05:22	0	6,000	6,000	0:10:58
14	14180820763	DD1310S	MOBIL	10/07/2018 06:39:30	10/07/2018 07:05:23	0	6,000	6,000	0:25:53
15	13180582410	DP1292EB	MOBIL	10/07/2018 05:38:20	10/07/2018 07:05:31	0	9,000	9,000	1:27:11
16	22180835585	DD1670RS	MOBIL	10/07/2018 06:56:08	10/07/2018 07:06:37	0	6,000	6,000	0:10:29
17	22180835575	DD12227BG	MOBIL	10/07/2018 06:52:05	10/07/2018 07:06:50	0	6,000	6,000	0:14:45

18	13180582504	DW1372BP	MOBIL	10/07/2018 06:53:56	10/07/2018 07:06:58	0	6,000	6,000	0:13:02
19	14180820746	DD231YU	MOBIL	10/07/2018 06:34:42	10/07/2018 07:07:35	0	6,000	6,000	0:32:53
20	14180820560	DD1165BM	MOBIL	10/07/2018 05:08:47	10/07/2018 07:08:00	0	9,000	9,000	1:59:13
21	13180582391	DD8417RJ	MOBIL	10/07/2018 05:22:52	10/07/2018 07:08:07	0	9,000	9,000	1:45:15
22	12180362279	DD1132DU	MOBIL	10/07/2018 06:57:22	10/07/2018 07:08:26	0	6,000	6,000	0:11:04
23	14180820739	DD503AH	MOBIL	10/07/2018 06:32:33	10/07/2018 07:08:47	0	6,000	6,000	0:36:14
24	12180362267	DD1508OW	MOBIL	10/07/2018 06:51:21	10/07/2018 07:09:15	0	6,000	6,000	0:17:54
25	13180582519	B1780NKK	MOBIL	10/07/2018 06:59:25	10/07/2018 07:09:37	0	6,000	6,000	0:10:12
26	13180582413	DD8489RT	MOBIL	10/07/2018 05:39:50	10/07/2018 07:10:26	0	9,000	9,000	1:30:36
27	14180820738	DD1421DY	MOBIL	10/07/2018 06:32:16	10/07/2018 07:10:40	0	6,000	6,000	0:38:24
28	22180835463	DP1086BA	MOBIL	10/07/2018 06:11:18	10/07/2018 07:11:06	0	6,000	6,000	0:59:48
29	13180582521	DD1876YW	MOBIL	10/07/2018 07:01:07	10/07/2018 07:11:08	0	6,000	6,000	0:10:01

Rata-rata Durasi Parkir

0:39:34

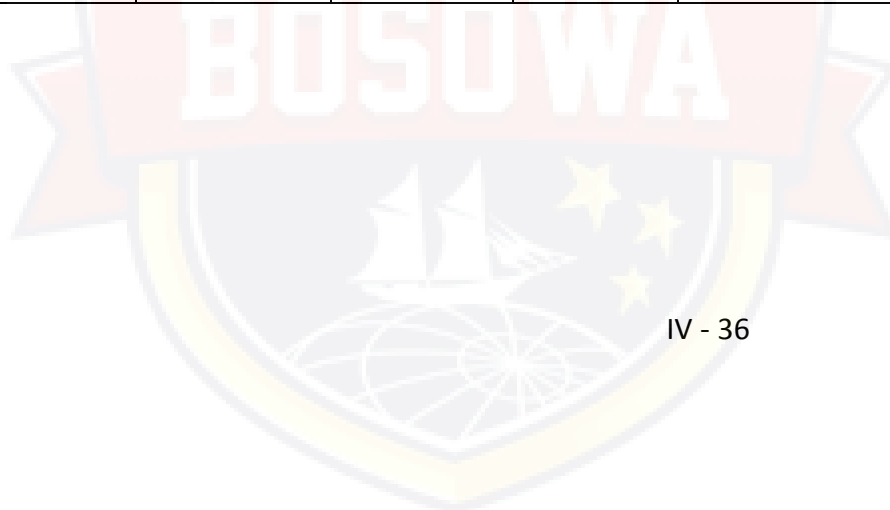

4.2 ANALISA DATA

4.2.1 Kebutuhan Tempat Parkir Pada Bandar Udara Sultan Hasanuddin

Berdasarkan Peraturan Direktur Jenderal Perhubungan Udara Nomor : SKEP/77/VI/2015 Tentang Persyaratan Teknis Pengoperasian Fasilitas Teknik Bandar Udara bahwa daya tampung parkir dihitung dari jumlah penumpang waktu sibuk. Namun untuk menghitung kebutuhan parkir digunakan data perbandingan kendaraan dan penumpang pada bulan Desember 2018 dikarenakan perhitungan sesuai SKEP/77/VI/2015 dianggap cocok digunakan pada masa perencanaan, maka didapat perhitungan sebagai berikut :

$$\frac{\text{Jumlah kendaraan selama bulan Desember 2018}}{\text{Jumlah penumpang selama bulan Desember 2018}} \times 100\% = \frac{600.147}{854.234} \times 100\% = 70,26\%$$

Maka sesuai tabel 4.2 diatas diperoleh jumlah penumpang jam sibuk adalah 6.225 orang, sehingga diperoleh jumlah kendaraan pada jam sibuk adalah $= 6.225 \times 70,26 \% = 4.373,41 \approx 4.374$ kendaraan (roda 2, 4 dan 6)

Untuk mencari jumlah perbandingan pengguna roda 2, 4 dan 6 diambil data jumlah pergerakan kendaraan yang beroperasi di Bandara Internasional Sultan Hasanuddin sesuai tabel 4.3 diatas yaitu :

Roda 2 = 191.999 kendaraan

Roda 4 = 404.888 kendaraan

Roda 6 = 3.260 kendaraan

Maka didapatkan perbandingan sebagai berikut :

$$\text{Roda 2} = \frac{191.999}{600.147} \times 100\% = 31,99\%$$

$$\text{Roda 4} = \frac{404.888}{600.147} \times 100\% = 67,46\%$$

$$\text{Roda 6} = \frac{3.260}{600.147} \times 100\% = 0,54\%$$

Sehingga diperoleh jumlah pengguna roda 4 pada jam sibuk adalah :

$$\text{Roda 4} = 67,46\% \times 4.374 = 2.950,91 \approx 2.951 \text{ kendaraan}$$

Namun jumlah kendaraan tersebut terdiri dari kendaraan yang parkir dan yang tidak parkir, sehingga perlu dicari jumlah kendaraan yang parkir berdasarkan data pada tabel 4.4. Perhitungan jumlah kendaraan yang parkir dan tidak parkir berdasarkan penumpang jam sibuk adalah sebagai berikut :

$$\text{Jumlah kendaraan parkir} = 401 \text{ kendaraan atau } 40,10\%$$

$$\text{Jumlah kendaraan tidak parkir} = 599 \text{ kendaraan atau } 59,99\%$$

Sehingga diperoleh jumlah kebutuhan ruang parkir berdasarkan penumpang pada jam sibuk yaitu :

$$\text{Jumlah kebutuhan ruang parkir} = 40,10\% \times 2.951 = 1.183 \text{ kendaraan}$$

4.2.2 Kapasitas Tempat Parkir Eksisting Sebelum Pengembangan Bandara Internasional Sultan Hasanuddin

Tempat parkir kendaraan eksisting di Bandara Internasional Sultan Hasanuddin merupakan pelataran parkir. Adapun kapasitas ruang parkir eksisting sebelum dilakukan pengembangan adalah sebagai berikut :

$$\text{Kapasitas tempat parkir roda 4} = 1.072 \text{ kendaraan}$$

4.2.3 Analisis Karakteristik Parkir

Karakteristik parkir yang akan dianalisis dalam tulisan ini adalah tempat parkir roda 4, dimana yang sebelumnya adalah pelataran parkir berubah menjadi gedung parkir.

4.2.3.1 Kapasitas Parkir

Kapasitas parkir kendaraan roda 4 yang disediakan oleh Bandara Sultan Hasanuddin setelah dilakukan pengembangan Bandara Internasional Sultan Hasanuddin adalah 624 kendaraan.

4.2.3.2 Durasi Parkir

Durasi parkir merupakan rentang waktu (lama waktu) kendaraan yang parkir.

$$\text{Durasi} = \text{Extime} - \text{Entime}$$

Keterangan:

Extime = Waktu saat kendaraan keluar lokasi parkir.

Entime = Waktu saat kendaraan masuk lokasi parkir.

Dari Tabel 4.5 Durasi Parkir Kendaraan Harian diperoleh total rata-rata durasi parkir adalah sebagai berikut ;

Tabel 4. 6 Tabel Durasi Parkir Rata-Rata

Sumber : Data PT. Angkasa Pura I (Persero)

NO	HARI/TANGGAL	DURASI PARKIR RATA-RATA
1	Minggu / 1 Juli 2018	0:50:51
2	Senin / 2 Juli 2018	1:31:35
3	Selasa / 3 Juli 2018	1:09:19

NO	HARI/TANGGAL	DURASI PARKIR RATA-RATA
4	Rabu / 4 Juli 2018	0:49:18
5	Kamis / 5 Juli 2018	2:37:29
6	Jumat / 6 Juli 2018	0:22:31
7	Sabtu / 7 Juli 2018	0:58:13
8	Minggu / 8 Juli 2018	0:48:21
9	Senin / 9 Juli 2018	2:11:07
10	Selasa / 10 Juli 2018	0:39:34
	RATA-RATA TOTAL	1:11:50

Jadi diperoleh durasi parkir rata-rata tiap kendaraan selama pengambilan data adalah 1:11:50 atau sama dengan 1,2 jam. Sehingga diperoleh kapasitas parkir yang dapat dilayani bandara internasional Sultan hasanuddin dengan tempat parkir yang baru tiap jam berdasarkan lama parkir adalah :

$$\text{Kapasitas parkir} = \frac{\text{Durasi parkir yang dicari}}{\text{Durasi parkir rata-rata}} \times \text{Jumlah ruang parkir}$$

$$\text{Kapasitas parkir} = \frac{1:00:00}{1:11:50} \times 624 = 521 \text{ kendaraan / jam}$$

Jika durasi parkir diterapkan terhadap ruang parkir eksisting sebelum pengembangan bandara dan berdasarkan jumlah penumpang jam sibuk, maka kapasitas parkir yang dapat dilayani bandara internasional Sultan hasanuddin tiap jam berdasarkan lama parkir adalah :

$$\text{Kapasitas parkir eksisting} = \frac{1:00:00}{1:11:50} \times 1.072 = 895 \text{ kendaraan / jam}$$

$$\text{Kebutuhan parkir pada jam sibuk} = \frac{1:00:00}{1:11:50} \times 1.184 = 989 \text{ kendaraan / jam}$$

Sehingga dari semua perhitungan diatas diperoleh hasil sebagai berikut :

NO	URAIAN	JAM SIBUK	EKSISTING	BARU (TAHAP I)
1	Ketersedian ruang parkir (kendaraan)	1.184	1.072	624
2	Kapasitas parkir Berdasarkan lama parkir (kendaraan / jam)	989	895	521

Dari tabel diatas, dapat dilihat bahwa kebutuhan ruang parkir pada saat jam sibuk adalah 1.184 kendaraan, ketersediaan ruang parkir eksisting sebelum dilakukan pengembangan mampu menampung 1.072 kendaraan, sedangkan ruang parkir yang tersedia sekarang (pengembangan tahap 1) adalah 624 kendaraan. Dan jika dianalisa lebih dalam terkait kapasitas ruang parkir berdasarkan lama parkir maka diperoleh kebutuhan ruang parkir pada saat jam sibuk adalah 989 kendaraan / jam, ketersediaan ruang parkir eksisting sebelum dilakukan pengembangan mampu menampung 896 kendaraan / jam, sedangkan ruang parkir yang tersedia sekarang (pengembangan tahap 1) hanya mampu menampung 522 kendaraan / jam.

BAB V

KESIMPULAN DAN SARAN

5.1 KESIMPULAN

1. Penyediaan ruang parkir pada pengembangan tahap 1 **tidak mampu menampung** seluruh kendaraan yang beroperasi baik terhadap kebutuhan penumpang pada jam sibuk maupun berdasarkan kapasitas eksisting (awal) sebelum pengembangan bandara.
2. Kapasitas ruang parkir yang dikembangkan pada tahap 1 **tidak mampu menampung** kendaraan sesuai lama parkir tiap kendaraan yang dilayani Bandar Udara Internasional Sultan Hasanuddin.

5.2 SARAN

Berdasarkan kesimpulan di atas, maka ada beberapa saran untuk peneliti selanjutnya, yaitu :

1. Kapasitas ruang parkir Bandara Internasional Sultan Hasanuddin perlu ditambah sesuai kebutuhan penumpang pada jam sibuk, atau minimal menyediakan sama dengan kapasitas eksisting sebelum bandara dilakukan pengembangan dengan memperhatikan lama parkir tiap kendaraan.
2. Setiap melakukan pembangunan fasilitas parkir disarankan agar selalu memperhatikan karakteristik parkir tiap kendaraan yang akan dilayani.

DAFTAR PUSTAKA

- Abubakar, I. dkk, 1998, **Pedoman Perencanaan dan Pengoperasian Fasilitas Parkir, Direktorat Jenderal Perhubungan Darat.** Jakarta.
- Anonymous, 1999, "**Rekayasa Lalu Lintas**", Direktorat Jendral Perhubungan Darat, Departemen Perhubungan.
- Direktorat Jenderal Perhubungan Darat. 1998. **Pedoman Perencanaan dan Pengoperasian Fasilitas Parkir.** Direktorat Bina Sistem Lalu Lintas Angkutan Kota.
- Keputusan Menteri Perhubungan Nomor : **KM 66 Tahun 1993**
Tentang Fasilitas Parkir Untuk Umum.
- Keputusan Menteri Perhubungan Nomor : **KM 4 Tahun 1994**
Tentang Tata Cara Parkir Kendaraan Bermotor di Jalan.
- Keputusan Direktur Jenderal Perhubungan Darat Nomor :
272/HK.105/DRJD/96
Tentang Pedoman Teknis Penyelenggaraan Fasilitas Parkir.
- Peraturan Direktur Jenderal Perhubungan Udara Nomor :
SKEP/77/VI/2005
Tentang Persyaratan Teknis Pengoperasian Fasilitas Teknik Bandar Udara.
- Hoobs, F.D. 1995. **Perencanaan Dan Teknik Lalu Lintas.** Diterjemahkan oleh Suprpto TM dan Waldijino. Gajah Mada University Press. Yogyakarta.
- Anonim, 1997, **Manual Kapasitas Jalan Indonesia (MKJI)**, Departemen Pekerjaan Umum, Direktorat Jenderal Bina Marga, Jakarta.
- Nugroho, Y.F. 2014. **Evaluasi Kebutuhan Ruang Parkir Mobil dan Motor – Studi Kasus Tempat Parkir FTI-FTSP Universitas Islam Indonesia.** Tugas Akhir. (Tidak Diterbitkan). Universitas Islam Indonesia. Yogyakarta.

LAMPIRAN

BOSOWA



LAPORAN TRAFFIC PESAWAT, PASSENGER, BAGASI, CARGO & POS
TAHUN 2014

BULAN	PESAWAT				PENUMPANG				BAGASI (KG)			K A R G O (KG)			POS (KG)		
	DOM	ARR	DEP	TOTAL	ARR	DEP	TRS	TOTAL	ARR	DEP	TOTAL	ARR	DEP	TOTAL	ARR	DEP	TOTAL
Januari	INT	30.00	30.00	60.00	3,809.00	3,507.00	-	7,316.00	52,202.00	40,743.00	92,945.00	2,449.00	54,448.00	56,897.00	-	-	-
	DOM	3,779.00	3,779.00	7,558.00	302,089.00	288,375.00	168,847.00	759,311.00	2,957,670.00	4,470,185.00	7,427,855.00	2,439,781.00	3,613,002.00	6,052,783.00	34,470.00	7,495.00	41,965.00
Februari	INT	29.00	29.00	58.00	3,051.00	3,096.00	-	6,147.00	44,550.00	38,011.00	82,561.00	11,076.00	73,973.00	85,049.00	-	-	-
	DOM	2,979.00	2,979.00	5,958.00	253,730.00	235,306.00	134,552.00	623,588.00	2,312,487.00	3,333,160.00	5,645,647.00	2,154,177.00	3,118,020.00	5,272,197.00	28,026.00	5,461.00	33,487.00
Maret	INT	30.00	30.00	60.00	3,140.00	3,052.00	-	6,192.00	44,685.00	32,856.00	77,541.00	18,117.00	79,646.00	97,763.00	-	-	-
	DOM	3,319.00	3,319.00	6,638.00	291,062.00	254,839.00	150,918.00	696,819.00	2,612,122.00	3,546,865.00	6,158,987.00	2,696,871.00	3,586,043.00	6,282,914.00	35,566.00	7,081.00	42,647.00
April	INT	29.00	29.00	58.00	3,365.00	3,077.00	-	6,442.00	48,606.00	33,427.00	82,033.00	3,314.00	73,393.00	76,707.00	-	-	-
	DOM	3,133.00	3,133.00	6,266.00	261,844.00	236,584.00	140,276.00	638,704.00	2,290,706.00	3,194,394.00	5,485,100.00	2,234,702.00	2,960,821.00	5,195,523.00	21,745.00	7,140.00	28,885.00
Mei	INT	31.00	30.00	61.00	3,505.00	3,175.00	-	6,680.00	51,811.00	36,193.00	88,004.00	442.00	83,490.00	83,932.00	-	-	-
	DOM	3,355.00	3,355.00	6,712.00	298,584.00	262,309.00	159,361.00	720,254.00	2,643,395.00	3,602,857.00	6,246,252.00	2,174,896.00	2,976,498.00	5,151,394.00	20,765.00	4,752.00	25,517.00
Juni	INT	29.00	30.00	59.00	3,375.00	3,383.00	-	6,758.00	49,861.00	39,633.00	89,494.00	1,226.00	88,471.00	89,697.00	-	-	-
	DOM	3,408.00	3,408.00	6,816.00	319,559.00	273,003.00	178,030.00	770,592.00	2,935,476.00	4,020,109.00	6,955,585.00	2,551,131.00	2,922,840.00	5,473,971.00	15,215.00	5,656.00	20,871.00
Juli	INT	29.00	29.00	58.00	3,346.00	2,830.00	-	6,176.00	51,711.00	31,511.00	83,222.00	350.00	70,987.00	71,337.00	-	-	-
	DOM	3,263.00	3,263.00	6,526.00	282,777.00	219,311.00	158,592.00	660,680.00	2,756,178.00	3,684,851.00	6,441,029.00	2,324,236.00	2,676,169.00	5,000,405.00	21,086.00	7,117.00	28,203.00
Agustus	INT	29.00	29.00	58.00	3,413.00	3,379.00	-	6,792.00	51,552.00	37,932.00	89,484.00	1,925.00	61,398.00	63,323.00	-	-	-
	DOM	3,671.00	3,671.00	7,342.00	326,286.00	307,391.00	183,845.00	817,522.00	2,986,623.00	4,719,701.00	7,706,324.00	2,135,162.00	2,421,385.00	4,556,547.00	8,405.00	6,560.00	14,965.00
September	INT	57.00	57.00	114.00	3,305.00	15,028.00	-	18,333.00	50,254.00	288,470.00	338,724.00	520.00	93,272.00	93,792.00	-	-	-
	DOM	3,448.00	3,448.00	6,896.00	295,684.00	245,172.00	165,467.00	706,323.00	2,570,922.00	3,525,380.00	6,096,302.00	2,381,517.00	2,865,118.00	5,246,635.00	11,494.00	7,246.00	18,740.00
Oktober	INT	50.00	49.00	99.00	11,515.00	3,191.00	-	14,706.00	288,936.00	35,017.00	323,953.00	5,372.00	82,491.00	87,863.00	-	-	-
	DOM	3,661.00	3,662.00	7,323.00	334,432.00	285,049.00	167,500.00	786,981.00	2,824,592.00	3,823,043.00	6,647,635.00	2,543,784.00	2,881,065.00	5,424,849.00	9,478.00	6,787.00	16,265.00
Nopember	INT	37.00	37.00	74.00	7,224.00	2,851.00	-	10,075.00	163,029.00	31,048.00	194,077.00	691.00	94,241.00	94,932.00	-	-	-
	DOM	3,518.00	3,518.00	7,036.00	324,267.00	272,093.00	165,921.00	762,281.00	2,738,908.00	3,778,853.00	6,517,761.00	2,700,662.00	3,145,201.00	5,845,863.00	11,191.00	6,536.00	17,727.00
Desember	INT	33.00	33.00	66.00	3,440.00	3,573.00	-	7,013.00	52,337.00	42,562.00	94,899.00	1,093.00	80,222.00	81,315.00	-	-	-
	DOM	3,726.00	3,726.00	7,452.00	344,803.00	268,260.00	169,838.00	782,901.00	3,039,347.00	3,825,439.00	6,864,786.00	2,703,507.00	3,366,686.00	6,070,193.00	21,863.00	6,013.00	27,876.00
TOTAL	INT	413.00	412.00	825.00	52,488.00	50,142.00	-	102,630.00	949,534.00	687,403.00	1,636,937.00	46,575.00	936,032.00	982,607.00	-	-	-
	DOM	41,260.00	41,261.00	82,523.00	3,635,117.00	3,147,692.00	1,943,147.00	8,725,956.00	32,668,426.00	45,524,837.00	78,193,263.00	29,040,426.00	36,532,848.00	65,573,274.00	239,304.00	77,844.00	317,148.00
TOTAL INT / DOM	INT			825.00				102,630.00			1,636,937.00		936,032.00	982,607.00			-
	DOM			82,523.00				8,725,956.00			78,193,263.00		36,532,848.00	65,573,274.00			317,148.00
GRAND TOTAL INT+DOM				83,348.00				8,828,586.00			79,830,200.00		66,555,881.00				317,148.00



LAPORAN TRAFFIC PESAWAT, PASSENGER, BAGASI, CARGO & POS
TAHUN 2015

BULAN	INT DOM	PESAWAT			PENUMPANG				BAGASI (KG)			K A R G O (KG)			POS (KG)		
		ARR	DEP	TOTAL	ARR	DEP	TRS	TOTAL	ARR	DEP	TOTAL	ARR	DEP	TOTAL	ARR	DEP	TOTAL
Januari	INT	29	29	58	3,484	3,097	-	6,581	55,669	34,984	90,653	647	71,603	72,250	-	-	-
	DOM	3,406	3,406	6,812	281,232	263,361	144,883	689,476	2,704,507	3,808,444	6,512,951	2,296,626	2,926,497	5,223,123	19,855	8,525	28,380
Februari	INT	28	27	55	2,804	2,492	-	5,296	48,869	28,738	77,607	195	54,678	54,873	-	-	-
	DOM	3,034	3,035	6,069	255,479	215,615	136,297	607,391	2,302,232	3,096,464	5,398,696	2,000,284	2,642,496	4,642,780	12,378	6,191	18,569
Maret	INT	36	36	72	3,344	3,304	-	6,648	55,329	39,625	94,954	1,071	95,222	96,293	-	-	-
	DOM	3,516	3,516	7,032	304,642	252,104	154,089	710,835	2,782,103	3,588,917	6,371,020	2,139,657	3,050,892	5,190,549	11,521	5,706	17,227
April	INT	51	52	103	5,728	5,811	81	11,620	106,448	77,130	183,578	636	87,989	88,625	-	-	-
	DOM	3,476	3,475	6,951	287,606	244,275	159,424	691,305	2,618,570	3,539,240	6,157,810	2,221,579	3,185,252	5,406,831	11,233	8,108	19,341
Mei	INT	46	47	93	5,397	5,209	32	10,638	95,422	60,965	156,387	110,590	320	110,910	-	-	-
	DOM	3,688	3,687	7,375	339,908	270,813	180,558	791,279	3,154,625	4,004,606	7,159,231	2,416,269	3,224,797	5,641,066	13,066	7,183	20,249
Juni	INT	38	37	75	4,445	3,951	1	8,397	73,946	48,112	122,058	201	95,759	95,960	-	-	-
	DOM	3,560	3,561	7,121	314,960	261,916	177,724	754,600	2,973,139	4,071,827	7,044,966	2,558,381	3,393,184	5,951,565	15,303	8,473	23,776
Juli	INT	37	36	73	4,337	3,376	-	7,713	74,424	41,280	115,704	90	78,268	78,358	-	-	-
	DOM	3,918	3,919	7,837	357,712	310,083	188,039	855,834	3,535,028	4,884,641	8,419,669	2,080,874	3,532,953	5,613,827	34,631	13,046	47,677
Agustus	INT	42	43	85	3,201	6,635	-	9,836	46,759	105,773	152,532	458	74,038	74,496	-	-	-
	DOM	3,919	3,918	7,837	334,527	322,395	190,088	847,010	2,996,169	4,771,726	7,767,895	2,049,014	3,755,939	5,804,953	9,739	15,050	24,789
September	INT	53	53	106	4,298	11,136	-	15,434	78,579	207,809	286,388	1,371	92,992	94,363	-	-	-
	DOM	3,633	3,633	7,266	298,263	256,963	177,471	732,697	2,583,781	3,851,806	6,435,587	2,040,077	3,854,460	5,894,537	13,046	12,099	25,145
Oktober	INT	55	54	109	13,929	3,072	-	17,001	363,019	35,358	398,377	331	78,646	78,977	-	-	-
	DOM	3,799	3,801	7,600	327,823	308,111	193,184	829,118	2,803,480	4,530,334	7,333,814	2,155,388	3,682,144	5,837,532	8,481	9,654	18,135
Nopember	INT	27	27	54	3,222	2,591	-	5,813	48,546	27,392	75,938	101	88,786	88,887	-	-	-
	DOM	3,800	3,800	7,600	327,104	292,622	200,125	819,851	2,706,372	4,386,139	7,092,511	2,242,726	3,814,578	6,057,304	10,254	11,159	21,413
Desember	INT	45	46	91	4,434	6,014	97	10,545	79,991	78,921	158,912	585	86,039	86,624	-	-	-
	DOM	4,038	4,037	8,075	362,707	306,862	187,950	857,519	3,129,710	4,423,136	7,552,846	2,612,310	3,931,698	6,544,008	14,497	8,154	22,651
TOTAL	INT	487	487	974	58,623	56,688	211	115,522	1,127,001	786,087	1,913,088	116,276	904,340	1,020,616	-	-	-
	DOM	43,787	43,788	87,575	3,791,963	3,305,120	2,089,832	9,186,915	34,289,716	48,957,280	83,246,996	26,813,185	40,994,890	67,808,075	174,004	113,348	287,352
TOTAL INT / DOM	INT			974				115,522			1,913,088			1,020,616			-
	DOM			87,575				9,186,915			83,246,996			67,808,075			287,352
GRAND TOTAL INT+DOM				88,549				9,302,437			85,160,084			68,828,691			287,352



LAPORAN TRAFFIC PESAWAT, PASSENGER, BAGASI, CARGO & POS
TAHUN 2016

BULAN	PESAWAT				PENUMPANG				BAGASI (KG)			K A R G O (KG)			P O S (KG)		
	INT	ARR	DEP	TOTAL	ARR	DEP	TRS	TOTAL	ARR	DEP	TOTAL	ARR	DEP	TOTAL	ARR	DEP	TOTAL
Januari	INT	46	47	93	6,348	6,371	25	12,744	112,843	79,637	192,480	120	63,821	63,941	-	-	-
	DOM	4,041	4,040	8,081	327,349	322,876	170,701	820,926	2,949,024	4,746,243	7,695,267	2,229,484	3,387,768	5,617,252	10,482	7,382	17,864
Februari	INT	44	45	89	6,451	6,858	-	13,309	117,256	89,685	206,941	46	50,177	50,223	-	-	-
	DOM	3,735	3,734	7,469	302,186	282,961	168,152	753,299	2,670,559	4,131,019	6,801,578	1,891,126	2,975,404	4,866,530	7,853	34,210	42,063
Maret	INT	46	50	96	9,097	10,256	-	19,353	166,545	123,539	290,084	229	99,455	99,684	-	-	-
	DOM	4,066	4,064	8,130	346,858	309,626	181,055	837,539	3,130,494	4,532,869	7,663,363	1,968,585	3,452,734	5,421,319	8,041	5,374	13,415
April	INT	47	46	93	9,604	8,958	-	18,562	208,237	112,761	320,998	2,122	159,870	161,992	-	-	-
	DOM	3,926	3,926	7,852	335,901	302,431	181,507	819,839	3,011,817	4,490,921	7,502,738	2,130,950	3,265,751	5,396,701	8,168	19,390	27,558
Mei	INT	49	49	98	8,526	7,518	-	16,044	182,181	86,703	268,884	2,842	122,872	125,714	-	-	-
	DOM	4,070	4,071	8,141	387,084	349,507	204,367	940,958	3,553,549	5,265,963	8,819,512	2,282,100	3,419,037	5,701,137	6,318	6,830	13,148
Juni	INT	38	37	75	4,861	4,156	-	9,017	93,809	49,981	143,790	55	89,980	90,035	-	-	-
	DOM	3,882	3,884	7,766	331,648	277,715	191,897	801,260	3,258,000	4,808,057	8,066,057	2,731,281	3,659,481	6,390,762	10,159	7,923	18,082
Juli	INT	33	33	66	4,568	3,740	-	8,308	75,763	41,639	117,402	140	23,937	24,077	-	-	-
	DOM	4,460	4,460	8,920	436,136	395,195	212,709	1,044,040	4,331,912	6,314,915	10,646,827	1,636,970	3,066,927	4,703,897	9,153	4,103	13,256
Agustus	INT	56	56	112	3,682	13,018	211	16,911	55,322	221,720	277,042	157	51,897	52,054	-	-	-
	DOM	4,171	4,172	8,343	368,602	318,159	207,264	894,025	3,602,365	5,525,495	9,127,860	2,088,773	4,418,396	6,507,169	7,851	6,112	13,963
September	INT	51	51	102	7,962	6,371	-	14,333	180,004	104,392	284,396	184	61,062	61,246	-	-	-
	DOM	4,066	4,067	8,133	372,500	323,990	185,198	881,688	3,656,665	5,350,224	9,006,889	2,173,960	4,297,802	6,471,762	7,548	5,173	12,721
Oktober	INT	61	57	118	11,731	4,748	-	16,479	293,296	51,456	344,752	4,069	84,991	89,060	-	-	-
	DOM	4,275	4,280	8,555	354,815	319,488	200,624	874,927	3,471,006	5,496,829	8,967,835	2,186,826	4,689,257	6,876,083	6,995	3,082	10,077
Nopember	INT	31	32	63	3,419	3,813	-	7,232	53,314	40,635	93,949	37	72,914	72,951	-	-	-
	DOM	4,356	4,355	8,711	369,895	318,297	210,086	898,278	3,566,762	5,581,290	9,148,052	2,427,410	4,235,981	6,663,391	5,909	5,209	11,118
Desember	INT	47	44	91	6,202	7,163	-	13,365	130,596	92,771	223,367	454	70,761	71,215	-	-	-
	DOM	4,722	4,714	9,436	449,209	350,815	224,455	1,024,479	4,501,286	6,315,800	10,817,086	2,623,958	4,187,739	6,811,697	11,800	7,328	19,128
TOTAL	INT	549	547	1,096	82,451	82,970	236	165,657	1,669,166	1,094,919	2,764,085	10,455	951,737	962,192	-	-	-
	DOM	49,770	49,767	99,537	4,382,183	3,871,060	2,338,015	10,591,258	41,703,439	62,559,625	104,263,064	26,371,423	45,056,277	71,427,700	100,277	112,116	212,393
TOTAL INT / DOM	INT			1,096				165,657			2,764,085			962,192			-
	DOM			99,537				10,591,258			104,263,064			71,427,700			212,393
GRAND TOTAL INT+DOM				100,633				10,756,915			107,027,149			72,389,892			212,393



LAPORAN TRAFFIC PESAWAT, PASSENGER, BAGASI, CARGO & POS
TAHUN 2017

BLN	INT DOM	PESAWAT			PENUMPANG			BAGASI (Kg)			KARGO (Kg)			POS (Kg)						
		DTG	BRK	JML	DTG	BRK	TRS	DTG	BRK	TRS	DTG	BRK	TRS	DTG	BRK	TRS	JML			
JANUARI	INT	60	59	119	8,699	8,109	-	16,808	194,694	98,451	-	293,145	85	52,363	-	52,448	-	-	-	-
	DOM	4,609	4,610	9,219	392,043	352,303	200,067	944,413	3,998,610	3,912,681	2,287,600	10,198,891	2,134,511	2,875,418	1,126,853	6,136,782	5,869	3,182	792	9,843
FEBRUARI	INT	54	55	109	11,050	11,245	-	22,295	264,077	147,265	-	411,342	111	99,183	-	99,294	-	-	-	-
	DOM	4,104	4,097	8,201	332,683	277,667	179,443	789,793	3,322,874	3,002,308	1,999,460	8,324,642	2,245,128	2,567,020	1,118,316	5,930,464	4,590	2,250	690	7,530
MARET	INT	61	60	121	14,189	13,859	-	28,048	354,032	187,234	-	541,266	1,302	116,347	-	117,649	-	-	-	-
	DOM	4,408	4,411	8,819	398,242	324,899	209,887	933,028	3,739,581	3,267,726	2,168,652	9,175,959	2,741,153	2,844,303	1,161,382	6,746,838	6,059	2,333	1,137	9,529
APRIL	INT	59	59	118	14,054	14,275	-	28,329	362,678	189,419	-	552,097	273	94,981	-	95,254	-	-	-	-
	DOM	4,390	4,388	8,778	397,886	321,736	209,501	929,123	3,814,756	3,298,294	2,227,094	9,340,144	2,511,914	2,871,020	1,166,543	6,549,477	6,737	3,556	960	11,253
MEI	INT	54	53	107	12,077	10,788	-	22,865	254,801	125,488	-	380,289	-	52,572	-	52,572	-	-	-	-
	DOM	4,563	4,568	9,131	413,517	339,579	222,741	975,837	3,999,052	3,461,688	2,391,290	9,852,030	2,674,064	3,179,976	1,235,990	7,090,030	6,680	4,814	1,266	12,760
JUNI	INT	36	35	71	5,075	3,737	-	8,812	92,723	42,754	-	135,477	6,250	54,068	-	60,318	-	-	-	-
	DOM	4,482	4,483	8,965	432,966	295,404	219,600	947,970	4,383,204	3,205,170	2,374,842	9,963,216	2,552,820	2,703,641	1,108,705	6,365,166	6,586	4,658	745	11,989
JULI	INT	38	37	75	4,770	6,495	-	11,265	76,042	99,815	-	175,857	4,424	65,356	-	69,780	-	-	-	-
	DOM	5,123	5,122	10,245	529,479	437,365	272,273	1,239,117	5,076,692	4,877,892	2,977,841	12,932,425	2,584,540	2,821,529	1,153,377	6,559,446	6,071	4,067	596	10,734
AGUSTUS	INT	61	62	123	3,897	17,429	-	21,326	61,369	311,146	-	372,515	2,221	69,896	-	72,117	-	-	-	-
	DOM	4,941	4,940	9,881	454,125	339,820	231,429	1,025,374	4,374,397	3,469,268	2,484,253	10,327,918	2,868,721	2,964,362	1,323,266	7,156,349	5,526	4,003	1,041	10,570
SEPTEMBER	INT	61	58	119	16,130	3,752	378	20,260	406,086	46,901	3,668	456,655	1,098	65,988	-	67,086	-	-	-	-
	DOM	4,823	4,823	9,646	447,680	363,580	226,988	1,038,248	4,288,503	3,804,125	2,441,399	10,534,027	2,579,705	2,643,380	1,165,249	6,388,334	5,858	5,183	634	11,675
OKTOBER	INT	45	43	88	7,466	4,273	-	11,739	160,863	48,314	-	209,177	603	48,687	-	49,290	-	-	-	-
	DOM	4,953	4,959	9,912	466,553	355,451	238,930	1,060,934	4,553,895	3,846,619	2,638,096	11,038,610	3,176,591	3,036,894	1,564,632	7,778,117	8,953	6,187	1,236	16,376
NOPEMBER	INT	41	45	86	5,193	7,472	-	12,665	103,774	88,385	-	192,159	2,113	46,938	-	49,051	-	-	-	-
	DOM	4,759	4,763	9,522	452,916	344,065	246,296	1,043,277	4,394,442	3,620,250	2,659,449	10,674,141	3,223,813	3,035,490	1,670,195	7,929,498	6,937	5,904	967	13,808
DESEMBER	INT	65	63	128	11,843	12,336	-	24,179	275,300	155,644	-	430,944	601	48,638	-	49,239	-	-	-	-
	DOM	5,168	5,164	10,332	517,464	366,189	254,868	1,138,521	4,979,426	3,837,879	2,787,400	11,604,705	3,626,287	3,570,643	1,749,726	8,946,656	6,483	4,496	727	11,706
TOTAL	INT	635	629	1,264	114,443	113,770	378	228,591	2,606,439	1,540,816	3,668	4,150,923	19,081	815,017	-	834,098	-	-	-	-
	DOM	56,323	56,328	112,651	5,235,554	4,118,058	2,712,023	12,065,635	50,925,432	43,603,900	29,437,376	123,966,708	32,919,247	35,113,676	15,544,234	83,577,157	76,349	50,633	10,791	137,773
TOTAL INT/DOM		56,958	56,957	113,915	5,349,997	4,231,828	2,712,401	12,294,226	53,531,871	45,144,716	29,441,044	128,117,631	32,938,328	35,928,693	15,544,234	84,411,255	76,349	50,633	10,791	137,773
GRAD TOTAL INT/DOM				113,915				12,294,226				128,117,631			84,411,255					137,773

84,549,028



DOMESTIK

BLN	PESAWAT			PENUMPANG				BAGASI (Kg)				KARGO (Kg)				POS (Kg)			
	DTG	BRK	JML	DTG	BRK	TRS	JML	DTG	BRK	TRS	JML	DTG	BRK	TRS	JML	DTG	BRK	TRS	JML
JANUARI	5,103	5,100	10,203	451,585	369,341	230,685	1,051,611	4,366,348	3,982,584	2,511,955	10,860,887	3,174,132	3,259,193	1,474,392	7,907,717	7,764	6,072	1,083	14,919
FEBRUARI	4,476	4,479	8,955	410,550	309,966	211,484	932,000	3,835,460	3,199,771	2,223,318	9,258,549	2,729,149	3,216,166	1,261,212	7,206,527	8,004	3,845	410	12,259
MARET	4,881	4,878	9,759	472,621	344,360	236,240	1,053,221	4,453,332	3,570,474	2,545,772	10,569,578	3,245,972	3,380,964	1,431,996	8,058,932	5,465	3,899	652	10,016
APRIL	4,804	4,809	9,613	489,315	358,725	248,751	1,096,791	4,595,147	3,694,085	2,643,868	10,933,100	3,123,302	3,115,567	1,480,717	7,719,586	4,949	5,963	994	11,906
MEI	4,579	4,583	9,162	463,338	329,273	243,236	1,035,847	4,343,324	3,361,144	2,616,103	10,320,571	3,467,081	2,904,933	1,538,279	7,910,293	3,596	8,650	1,347	13,593
JUNI	5,142	5,143	10,285	546,769	378,040	250,094	1,174,903	5,272,456	3,926,174	2,702,568	11,901,198	2,551,810	2,321,635	1,245,372	6,118,817	8,589	18,260	1,880	28,729
JULI	5,208	5,221	10,429	578,723	431,176	295,259	1,305,158	5,435,071	4,415,211	3,195,073	13,045,355	3,186,203	3,098,048	1,464,137	7,748,388	9,087	9,651	604	19,342
AGUSTUS	5,094	5,092	10,186	535,650	361,565	267,992	1,165,207	5,055,838	3,753,321	2,953,951	11,763,110	3,332,841	2,999,566	1,467,251	7,799,658	7,360	5,110	2,377	14,847
SEPTEMBER	4,900	4,892	9,792	527,226	364,526	258,163	1,149,915	4,813,211	3,742,264	2,730,378	11,285,853	3,480,564	2,656,776	1,501,119	7,638,459	6,384	8,499	1,637	16,520
OKTOBER	5,021	5,021	10,042	555,778	376,134	262,020	1,193,932	5,067,016	3,812,914	2,810,650	11,690,580	3,987,664	2,829,308	1,635,495	8,452,467	8,105	5,034	1,452	14,591
NOVEMBER	4,657	4,658	9,315	500,306	338,317	239,062	1,077,685	4,649,827	3,384,863	2,536,499	10,571,189	3,648,859	2,957,566	1,559,813	8,166,238	11,687	10,900	1,355	23,942
DESEMBER	4,695	4,694	9,389	513,494	320,828	233,246	1,067,568	4,796,129	3,321,594	2,448,408	10,566,131	3,640,469	3,146,615	1,622,669	8,409,753	21,826	16,100	3,015	40,941
TOTAL DOM	58,560	58,570	117,130	6,045,355	4,282,251	2,976,232	13,303,838	56,683,159	44,164,399	31,918,543	132,766,101	39,568,046	35,886,337	17,682,452	93,136,835	102,816	101,983	16,806	221,605

INTERNASIONAL

BLN	PESAWAT			PENUMPANG				BAGASI (Kg)				KARGO (Kg)				POS (Kg)			
	DTG	BRK	JML	DTG	BRK	TRS	JML	DTG	BRK	TRS	JML	DTG	BRK	TRS	JML	DTG	BRK	TRS	JML
JANUARI	65	66	131	9,794	8,200	0	17,994	207,059	102,426	0	309,485	1,022	52,090	0	53,112	0	0	0	0
FEBRUARI	57	57	114	7,740	8,736	0	16,476	159,959	113,934	0	273,893	20,323	45,856	0	66,179	0	0	0	0
MARET	76	78	154	13,633	14,945	0	28,578	308,175	194,606	0	502,781	1,724	41,903	0	43,627	0	0	0	0
APRIL	77	71	148	15,053	14,254	0	29,307	355,345	178,575	0	533,920	1,668	62,829	0	64,497	2,500	470	0	2,970
MEI	61	60	121	10,438	6,963	0	17,401	237,047	82,033	0	319,080	2,645	59,980	0	62,625	1,600	0	0	1,600
JUNI	33	34	67	4,394	4,288	0	8,682	80,254	49,943	0	130,197	3	48,753	0	48,756	0	0	0	0
JULI	53	49	102	4,372	11,802	0	16,174	68,179	191,353	0	259,532	254	68,372	0	68,626	0	0	0	0
AGUSTUS	58	58	116	6,497	12,228	0	18,725	134,769	205,885	0	340,654	356	66,298	0	66,654	0	0	0	0
SEPTEMBER	61	62	123	17,635	4,180	0	21,815	449,999	47,570	0	497,569	2,499	53,969	0	56,468	0	0	0	0
OKTOBER	39	42	81	5,917	8,617	0	14,534	108,444	101,209	0	209,653	175	54,644	0	54,819	1,600	1,400	0	3,000
NOVEMBER	66	64	130	12,250	11,864	27	24,141	236,822	149,770	128	386,720	2,186	47,214	0	49,400	3,251	1,600	0	4,851
DESEMBER	64	62	126	10,054	9,858	193	20,105	203,545	131,728	1,765	337,038	274	45,669	0	45,943	4,800	2,100	150	7,050
TOTAL INT'L	710	703	1,413	117,777	115,935	220	233,932	2,549,597	1,549,032	1,893	4,100,522	33,129	647,577	0	680,706	13,751	5,570	150	19,471
DOM & INT'L	59,270	59,273	118,543	6,163,132	4,398,186	2,976,452	13,537,770	59,232,756	45,713,431	31,920,436	136,866,623	39,601,175	36,533,914	17,682,452	93,817,541	116,567	107,553	16,956	241,076

STATISTIK LALU LINTAS ANGKUTAN UDARA TAHUN 2019

DOMESTIK

BULAN	PESAWAT			PENUMPANG				BAGASI (Kg)				KARGO (Kg)				POS (Kg)			
	DTG	BRK	JML	DTG	BRK	TRS	JML	DTG	BRK	TRS	JML	DTG	BRK	TRS	JML	DTG	BRK	TRS	JML
JANUARI	4,140	4,134	8,274	408,683	299,845	185,683	894,211	3,477,741	3,033,624	1,801,008	8,312,373	3,137,124	2,574,515	1,247,841	6,959,480	16,776	16,179	2,348	35,303
FEBRUARI	3,556	3,561	7,117	344,515	242,539	152,679	739,733	2,359,193	2,009,402	1,165,186	5,533,781	2,410,014	1,975,519	977,519	5,363,052	12,420	17,648	1,437	31,505
MARET	3,896	3,887	7,783	394,161	261,757	173,459	829,377	2,325,903	1,890,938	1,138,773	5,355,614	2,765,817	2,014,456	1,219,362	5,999,635	13,568	12,360	1,620	27,548
APRIL	3,768	3,770	7,538	363,351	246,228	153,915	763,494	2,186,292	1,762,106	1,007,827	4,956,225	2,719,920	1,889,488	1,134,678	5,744,086	8,676	8,011	1,039	17,726
MEI	3,835	3,836	7,671	352,951	221,687	160,945	735,583	2,218,520	1,599,162	1,069,870	4,887,552	3,012,752	1,955,658	1,216,814	6,185,224	17,807	11,106	1,178	30,091
JUNI	4,085	4,090	8,175	422,796	306,103	178,195	907,094	2,731,370	2,474,540	1,184,823	6,390,733	1,749,435	1,351,898	738,935	3,840,268	9,294	10,492	1,446	21,232
JULI	4,289	4,289	8,578	437,941	307,917	202,733	948,591	2,766,117	2,426,024	1,429,337	6,621,478	2,320,827	2,128,814	1,058,370	5,508,011	19,762	12,885	1,559	34,206
AGUSTUS	4,250	4,249	8,499	428,651	291,482	190,390	910,523	2,420,539	2,011,798	1,252,250	5,684,587	2,234,491	1,649,452	978,880	4,862,823	17,258	8,322	2,592	28,172
SEPTEMBER	3,981	3,989	7,970	426,031	289,609	182,362	898,002	2,496,230	2,016,871	1,180,191	5,693,292	2,187,717	1,586,363	895,935	4,670,015	10,122	6,654	1,815	18,591
OKTOBER	4,148	4,137	8,285	446,824	295,343	188,053	930,220	2,551,649	1,911,880	1,191,117	5,654,646	2,462,850	1,485,018	922,239	4,870,107	11,125	5,137	508	16,770
NOVEMBER	3,997	4,000	7,997	448,469	299,358	195,082	942,909	2,746,880	2,029,600	1,251,362	6,027,842	2,419,607	1,617,757	930,891	4,968,255	6,277	8,390	1,359	16,026
DESEMBER	4,170	4,172	8,342	466,519	291,897	190,282	948,698	2,956,711	2,060,540	1,222,201	6,239,452	2,451,860	1,904,149	1,079,947	5,435,956	7,844	10,199	980	19,023
TOTAL DOM	48,115	48,114	96,229	4,940,892	3,353,765	2,153,778	10,448,435	31,237,145	25,226,485	14,893,945	71,357,575	29,872,414	22,133,087	12,401,411	64,406,912	150,929	127,383	17,881	296,193

INTERNASIONAL

BULAN	PESAWAT			PENUMPANG				BAGASI (Kg)				KARGO (Kg)				POS (Kg)			
	DTG	BRK	JML	DTG	BRK	TRS	JML	DTG	BRK	TRS	JML	DTG	BRK	TRS	JML	DTG	BRK	TRS	JML
JANUARI	56	65	121	10,389	11,587	152	22,128	223,539	145,382	2,091	371,012	1,268	50,826	0	52,094	4,000	1,600	800	6,400
FEBRUARI	71	69	140	13,983	13,894	0	27,877	295,162	156,808	0	451,970	811	44,606	0	45,417	3,200	600	0	3,800
MARET	81	81	162	17,744	17,243	198	35,185	378,908	205,073	3,865	587,846	120	88,616	0	88,736	4,150	0	0	4,150
APRIL	72	71	143	13,638	13,375	0	27,013	282,745	145,888	0	428,633	524	76,938	0	77,462	0	600	0	600
MEI	57	53	110	9,725	8,045	0	17,770	192,744	93,339	906	286,989	4,340	98,624	0	102,964	800	0	0	800
JUNI	45	46	91	7,279	6,382	331	13,992	128,874	65,297	1,908	196,079	229	44,654	789	45,672	0	0	0	0
JULI	84	84	168	6,685	21,974	0	28,659	91,515	354,605	0	446,120	779	85,057	0	85,836	0	0	0	0
AGUSTUS	70	71	141	14,296	8,869	0	23,165	318,011	125,308	0	443,319	7,931	65,602	0	73,533	50	0	0	50
SEPTEMBER	79	76	155	16,388	8,649	136	25,173	378,915	87,363	2,179	468,457	538	81,997	0	82,535	500	800	0	1,300
OKTOBER	71	79	150	14,636	18,232	321	33,189	298,014	215,445	2,744	516,203	0	81,064	0	81,064	800	3,350	0	4,150
NOVEMBER	75	74	149	15,977	14,209	0	30,186	367,404	152,620	0	520,024	3,301	84,077	0	87,378	800	0	0	800
DESEMBER	68	66	134	12,252	12,037	0	24,289	277,066	137,360	1,164	415,590	41	114,840	0	114,881	0	0	0	0
TOTAL INT'L	829	835	1,664	152,992	154,496	1,138	308,626	3,232,897	1,884,488	14,857	5,132,242	19,882	916,901	789	937,572	14,300	6,950	800	22,050
GRAND TOTAL DOM & INT'L	48,944	48,949	97,893	5,093,884	3,508,261	2,154,916	10,757,061	34,470,042	27,110,973	14,908,802	76,489,817	29,892,296	23,049,988	12,402,200	65,344,484	165,229	134,333	18,681	318,243

LAPORAN PERGERAKAN LALU LINTAS ANGKUTAN UDARA
JAM PUNCAK TERMINAL PENUMPANG (LOCAL TIME)

TAPOR- UPG

APST - 06

BANDARA : INTERNASIONAL SULTAN HASANUDDIN

Penumpang Terpadat

	KEBERANGKATAN			KEDATANGAN		
	TANGGAL	JAM	JML. PAX	TANGGAL	JAM	JML. PAX

January - 2018

DOMESTIK	TANGGAL	JAM	JML. PAX	TANGGAL	JAM	JML. PAX
	Monday01/	09.01 - 10.00	2,019	Monday01/	13.01 - 14.00	1,388
	Tuesday02/	10.01 - 11.00	2,069	Tuesday02/	12.01 - 13.00	1,393
	Wednesday03/	10.01 - 11.00	2,493	Wednesday03/	13.01 - 14.00	1,757
	Thursday04/	10.01 - 11.00	2,148	Thursday04/	13.01 - 14.00	1,597
	Friday05/	10.01 - 11.00	2,349	Friday05/	13.01 - 14.00	1,372
	Saturday06/	14.01 - 15.00	2,246	Saturday06/	12.01 - 13.00	1,365
	Sunday07/	14.01 - 15.00	2,472	Sunday07/	13.01 - 14.00	1,473
	Monday08/	10.01 - 11.00	2,293	Monday08/	18.01 - 19.00	1,167
	Tuesday09/	10.01 - 11.00	1,666	Tuesday09/	08.01 - 09.00	1,498
	Wednesday10/	10.01 - 11.00	2,514	Wednesday10/	13.01 - 14.00	1,587
	Thursday11/	10.01 - 11.00	2,326	Thursday11/	15.01 - 16.00	1,232
	Friday12/	10.01 - 11.00	2,381	Friday12/	08.01 - 09.00	1,650
	Saturday13/	09.01 - 10.00	1,539	Saturday13/	13.01 - 14.00	1,439
	Sunday14/	10.01 - 11.00	2,129	Sunday14/	14.01 - 15.00	1,331
	Monday15/	10.01 - 11.00	2,249	Monday15/	13.01 - 14.00	1,345
	Tuesday16/	10.01 - 11.00	1,895	Tuesday16/	13.01 - 14.00	1,552
	Wednesday17/	10.01 - 11.00	1,983	Wednesday17/	13.01 - 14.00	1,331
	Thursday18/	09.01 - 10.00	1,621	Thursday18/	16.01 - 17.00	1,412
	Friday19/	10.01 - 11.00	2,041	Friday19/	08.01 - 09.00	1,120
	Saturday20/	10.01 - 11.00	1,656	Saturday20/	13.01 - 14.00	1,485
	Sunday21/	14.01 - 15.00	1,833	Sunday21/	13.01 - 14.00	1,350
	Monday22/	10.01 - 11.00	1,639	Monday22/	12.01 - 13.00	1,164
	Tuesday23/	14.01 - 15.00	1,711	Tuesday23/	13.01 - 14.00	1,261
	Wednesday24/	10.01 - 11.00	1,982	Wednesday24/	13.01 - 14.00	1,202
	Thursday25/	10.01 - 11.00	2,192	Thursday25/	14.01 - 15.00	1,612

	KEBERANGKATAN			KEDATANGAN		
	TANGGAL	JAM	JML. PAX	TANGGAL	JAM	JML. PAX
	Friday26/	10.01 - 11.00	2,107	Friday26/	16.01 - 17.00	1,495
	Saturday27/	14.01 - 15.00	1,639	Saturday27/	08.01 - 09.00	1,591
	Sunday28/	14.01 - 15.00	2,224	Sunday28/	08.01 - 09.00	1,196
	Monday29/	10.01 - 11.00	1,762	Monday29/	12.01 - 13.00	1,120
	Tuesday30/	09.01 - 10.00	1,682	Tuesday30/	12.01 - 13.00	1,081
	Wednesday31/	10.01 - 11.00	2,130	Wednesday31/	13.01 - 14.00	1,198
INTERNASIONAL	Monday01/	12.01 - 13.00	168	Monday01/	11.01 - 12.00	128
	Tuesday02/	05.01 - 06.00	126	Tuesday02/	17.01 - 18.00	125
	Wednesday03/	11.01 - 12.00	178	Wednesday03/	11.01 - 12.00	481
	Thursday04/	11.01 - 12.00	128	Thursday04/	12.01 - 13.00	270
	Friday05/	13.01 - 14.00	173	Friday05/	12.01 - 13.00	157
	Saturday06/	14.01 - 15.00	172	Saturday06/	12.01 - 13.00	410
	Sunday07/	12.01 - 13.00	177	Sunday07/	10.01 - 11.00	381
	Monday08/	12.01 - 13.00	179	Monday08/	11.01 - 12.00	169
	Tuesday09/	05.01 - 06.00	250	Tuesday09/	12.01 - 13.00	448
	Wednesday10/	12.01 - 13.00	164	Wednesday10/	11.01 - 12.00	162
	Thursday11/	11.01 - 12.00	125	Thursday11/	10.01 - 11.00	95
	Friday12/	11.01 - 12.00	176	Friday12/	10.01 - 11.00	152
	Saturday13/	14.01 - 15.00	252	Saturday13/	-	
	Sunday14/	11.01 - 12.00	165	Sunday14/	14.01 - 15.00	174
	Monday15/	12.01 - 13.00	159	Monday15/	11.01 - 12.00	150
	Tuesday16/	05.01 - 06.00	180	Tuesday16/	-	
	Wednesday17/	11.01 - 12.00	141	Wednesday17/	12.01 - 13.00	171
	Thursday18/	11.01 - 12.00	127	Thursday18/	10.01 - 11.00	96
	Friday19/	11.01 - 12.00	160	Friday19/	11.01 - 12.00	148
	Saturday20/	08.01 - 09.00	387	Saturday20/	12.01 - 13.00	48
	Sunday21/	12.01 - 13.00	167	Sunday21/	10.01 - 11.00	249
	Monday22/	12.01 - 13.00	163	Monday22/	11.01 - 12.00	137
	Tuesday23/	05.01 - 06.00	203	Tuesday23/	17.01 - 18.00	84
	Wednesday24/	12.01 - 13.00	162	Wednesday24/	12.01 - 13.00	252
	Thursday25/	12.01 - 13.00	123	Thursday25/	10.01 - 11.00	69

KEBERANGKATAN			KEDATANGAN		
TANGGAL	JAM	JML. PAX	TANGGAL	JAM	JML. PAX
Friday26/	12.01 - 13.00	167	Friday26/	11.01 - 12.00	162
Saturday27/	14.01 - 15.00	254			
Sunday28/	11.01 - 12.00	175	Sunday28/	09.01 - 10.00	181
Monday29/	11.01 - 12.00	240	Monday29/	11.01 - 12.00	164
Tuesday30/	05.01 - 06.00	42			
Wednesday31/	11.01 - 12.00	574	Wednesday31/	09.01 - 10.00	378

February - 2018

DOMESTIK

TANGGAL	JAM	JML. PAX	TANGGAL	JAM	JML. PAX
Thursday01/	10.01 - 11.00	2,034	Thursday01/	16.01 - 17.00	1,310
Friday02/	10.01 - 11.00	1,891	Friday02/	13.01 - 14.00	1,411
Saturday03/	15.01 - 16.00	2,127	Saturday03/	08.01 - 09.00	1,243
Sunday04/	14.01 - 15.00	2,191	Sunday04/	12.01 - 13.00	1,398
Monday05/	10.01 - 11.00	1,987	Monday05/	12.01 - 13.00	1,265
Tuesday06/	10.01 - 11.00	1,442	Tuesday06/	13.01 - 14.00	1,186
Wednesday07/	10.01 - 11.00	2,280	Wednesday07/	13.01 - 14.00	1,456
Thursday08/	10.01 - 11.00	2,150	Thursday08/	08.01 - 09.00	1,651
Friday09/	10.01 - 11.00	2,142	Friday09/	17.01 - 18.00	1,148
Saturday10/	10.01 - 11.00	1,906	Saturday10/	12.01 - 13.00	1,467
Sunday11/	15.01 - 16.00	1,876	Sunday11/	12.01 - 13.00	1,281
Monday12/	10.01 - 11.00	1,646	Monday12/	14.01 - 15.00	1,119
Tuesday13/	15.01 - 16.00	1,961	Tuesday13/	14.01 - 15.00	1,536
Wednesday14/	10.01 - 11.00	1,889	Wednesday14/	13.01 - 14.00	1,563
Thursday15/	09.01 - 10.00	1,639	Thursday15/	13.01 - 14.00	2,074
Friday16/	14.01 - 15.00	1,777	Friday16/	12.01 - 13.00	1,656
Saturday17/	14.01 - 15.00	1,593	Saturday17/	07.01 - 08.00	1,069
Sunday18/	10.01 - 11.00	2,454	Sunday18/	13.01 - 14.00	1,724
Monday19/	15.01 - 16.00	2,930	Monday19/	08.01 - 09.00	1,628
Tuesday20/	10.01 - 11.00	1,966	Tuesday20/	17.01 - 18.00	1,336
Wednesday21/	10.01 - 11.00	2,321	Wednesday21/	12.01 - 13.00	1,660
Thursday22/	09.01 - 10.00	1,771	Thursday22/	12.01 - 13.00	1,324
Friday23/	15.01 - 16.00	2,175	Friday23/	08.01 - 09.00	1,278

	KEBERANGKATAN			KEDATANGAN		
	TANGGAL	JAM	JML. PAX	TANGGAL	JAM	JML. PAX
	Saturday24/	15.01 - 16.00	1,712	Saturday24/	14.01 - 15.00	1,282
	Sunday25/	15.01 - 16.00	1,884	Sunday25/	17.01 - 18.00	1,413
	Monday26/	10.01 - 11.00	1,860	Monday26/	08.01 - 09.00	1,703
	Tuesday27/	15.01 - 16.00	1,566	Tuesday27/	14.01 - 15.00	1,230
	Wednesday28/	10.01 - 11.00	2,386	Wednesday28/	08.01 - 09.00	1,313
INTERNASIONAL	Thursday01/	12.01 - 13.00	144	Thursday01/	11.01 - 12.00	48
	Friday02/	11.01 - 12.00	146	Friday02/	11.01 - 12.00	157
	Saturday03/	07.01 - 08.00	151	Saturday03/	-	
	Sunday04/	11.01 - 12.00	142	Sunday04/	13.01 - 14.00	156
	Monday05/	11.01 - 12.00	191	Monday05/	11.01 - 12.00	145
	Tuesday06/	06.01 - 07.00	286	Tuesday06/	19.01 - 20.00	70
	Wednesday07/	11.01 - 12.00	150	Wednesday07/	09.01 - 10.00	251
	Thursday08/	11.01 - 12.00	115	Thursday08/	10.01 - 11.00	81
	Friday09/	12.01 - 13.00	151	Friday09/	11.01 - 12.00	157
	Saturday10/	07.01 - 08.00	163			
	Sunday11/	15.01 - 16.00	428	Sunday11/	12.01 - 13.00	426
	Monday12/	12.01 - 13.00	139	Monday12/	11.01 - 12.00	181
	Tuesday13/	06.01 - 07.00	343	Tuesday13/	17.01 - 18.00	52
	Wednesday14/	11.01 - 12.00	149	Wednesday14/	09.01 - 10.00	150
	Thursday15/	07.01 - 08.00	182	Thursday15/	10.01 - 11.00	124
	Friday16/	11.01 - 12.00	143	Friday16/	11.01 - 12.00	168
	Saturday17/	08.01 - 09.00	351			
	Sunday18/	12.01 - 13.00	144	Sunday18/	09.01 - 10.00	284
	Monday19/	12.01 - 13.00	148	Monday19/	11.01 - 12.00	147
	Tuesday20/	05.01 - 06.00	351	Tuesday20/	17.01 - 18.00	54
	Wednesday21/	11.01 - 12.00	159	Wednesday21/	09.01 - 10.00	163
	Thursday22/	10.01 - 11.00	393	Thursday22/	12.01 - 13.00	428
	Friday23/	11.01 - 12.00	169	Friday23/	11.01 - 12.00	184
	Saturday24/	14.01 - 15.00	452	Saturday24/	12.01 - 13.00	111
	Sunday25/	11.01 - 12.00	148	Sunday25/	09.01 - 10.00	342
	Monday26/	12.01 - 13.00	168	Monday26/	11.01 - 12.00	163

	KEBERANGKATAN			KEDATANGAN		
	TANGGAL	JAM	JML. PAX	TANGGAL	JAM	JML. PAX
	Tuesday27/	06.01 - 07.00	316	Tuesday27/	17.01 - 18.00	45
	Wednesday28/	12.01 - 13.00	179	Wednesday28/	12.01 - 13.00	333

March - 2018

DOMESTIK

TANGGAL	JAM	JML. PAX	TANGGAL	JAM	JML. PAX
Thursday01/	10.01 - 11.00	2,258	Thursday01/	13.01 - 14.00	1,294
Friday02/	10.01 - 11.00	1,850	Friday02/	11.01 - 12.00	1,225
Saturday03/	10.01 - 11.00	2,076	Saturday03/	14.01 - 15.00	1,452
Sunday04/	15.01 - 16.00	1,880	Sunday04/	12.01 - 13.00	1,572
Monday05/	10.01 - 11.00	2,029	Monday05/	12.01 - 13.00	1,517
Tuesday06/	14.01 - 15.00	1,764	Tuesday06/	12.01 - 13.00	1,121
Wednesday07/	10.01 - 11.00	2,329	Wednesday07/	08.01 - 09.00	1,467
Thursday08/	15.01 - 16.00	2,560	Thursday08/	13.01 - 14.00	1,303
Friday09/	14.01 - 15.00	1,638	Friday09/	10.01 - 11.00	1,112
Saturday10/	14.01 - 15.00	1,606	Saturday10/	12.01 - 13.00	1,625
Sunday11/	15.01 - 16.00	2,340	Sunday11/	13.01 - 14.00	1,412
Monday12/	11.01 - 12.00	1,641	Monday12/	07.01 - 08.00	1,346
Tuesday13/	15.01 - 16.00	1,865	Tuesday13/	13.01 - 14.00	1,339
Wednesday14/	10.01 - 11.00	2,321	Wednesday14/	13.01 - 14.00	1,608
Thursday15/	10.01 - 11.00	1,940	Thursday15/	13.01 - 14.00	1,355
Friday16/	10.01 - 11.00	1,935	Friday16/	11.01 - 12.00	1,513
Saturday17/	10.01 - 11.00	1,706	Saturday17/	16.01 - 17.00	1,292
Sunday18/	15.01 - 16.00	2,001	Sunday18/	16.01 - 17.00	1,328
Monday19/	10.01 - 11.00	2,132	Monday19/	15.01 - 16.00	1,266
Tuesday20/	10.01 - 11.00	2,363	Tuesday20/	14.01 - 15.00	1,224
Wednesday21/	10.01 - 11.00	2,471	Wednesday21/	15.01 - 16.00	1,399
Thursday22/	15.01 - 16.00	2,090	Thursday22/	13.01 - 14.00	1,684
Friday23/	18.01 - 19.00	1,838	Friday23/	08.01 - 09.00	1,452
Saturday24/	10.01 - 11.00	2,056	Saturday24/	13.01 - 14.00	1,905
Sunday25/	10.01 - 11.00	2,044	Sunday25/	13.01 - 14.00	1,474
Monday26/	10.01 - 11.00	2,512	Monday26/	16.01 - 17.00	1,387

	KEBERANGKATAN			KEDATANGAN		
	TANGGAL	JAM	JML. PAX	TANGGAL	JAM	JML. PAX
	Tuesday27/	14.01 - 15.00	1,933	Tuesday27/	16.01 - 17.00	1,341
	Wednesday28/	10.01 - 11.00	2,245	Wednesday28/	13.01 - 14.00	1,540
	Thursday29/	15.01 - 16.00	2,683	Thursday29/	13.01 - 14.00	1,835
	Friday30/	10.01 - 11.00	2,004	Friday30/	08.01 - 09.00	1,751
	Saturday31/	10.01 - 11.00	1,799	Saturday31/	15.01 - 16.00	1,305
INTERNASIONAL	Thursday01/	10.01 - 11.00	399	Thursday01/	10.01 - 11.00	61
	Friday02/	12.01 - 13.00	174	Friday02/	12.01 - 13.00	490
	Sunday04/	14.01 - 15.00	361	Sunday04/	09.01 - 10.00	351
	Monday05/	12.01 - 13.00	167	Monday05/	11.01 - 12.00	151
	Tuesday06/	06.01 - 07.00	392	Tuesday06/	17.01 - 18.00	46
	Wednesday07/	11.01 - 12.00	163	Wednesday07/	12.01 - 13.00	447
	Thursday08/	12.01 - 13.00	144	Thursday08/	11.01 - 12.00	94
	Friday09/	12.01 - 13.00	148	Friday09/	11.01 - 12.00	569
	Saturday10/	14.01 - 15.00	426	Saturday10/	02.01 - 03.00	213
	Sunday11/	12.01 - 13.00	156	Sunday11/	09.01 - 10.00	351
	Monday12/	11.01 - 12.00	259	Monday12/	11.01 - 12.00	170
	Tuesday13/	06.01 - 07.00	381	Tuesday13/	17.01 - 18.00	129
	Wednesday14/	15.01 - 16.00	205	Wednesday14/	12.01 - 13.00	433
	Thursday15/	15.01 - 16.00	273	Thursday15/	12.01 - 13.00	411
	Friday16/	14.01 - 15.00	155	Friday16/	13.01 - 14.00	212
	Saturday17/	15.01 - 16.00	429	Saturday17/	11.01 - 12.00	82
	Sunday18/	20.01 - 21.00	340	Sunday18/	09.01 - 10.00	392
	Monday19/	12.01 - 13.00	153	Monday19/	11.01 - 12.00	207
	Tuesday20/	06.01 - 07.00	502	Tuesday20/	17.01 - 18.00	129
	Wednesday21/	14.01 - 15.00	177	Wednesday21/	09.01 - 10.00	363
	Thursday22/	07.01 - 08.00	245	Thursday22/	15.01 - 16.00	163
	Friday23/	12.01 - 13.00	148	Friday23/	13.01 - 14.00	205
	Saturday24/	14.01 - 15.00	449	Saturday24/	12.01 - 13.00	98
	Sunday25/	15.01 - 16.00	437	Sunday25/	10.01 - 11.00	498
	Monday26/	17.01 - 18.00	145	Monday26/	16.01 - 17.00	138
	Tuesday27/	06.01 - 07.00	400	Tuesday27/	18.01 - 19.00	51

KEBERANGKATAN			KEDATANGAN		
TANGGAL	JAM	JML. PAX	TANGGAL	JAM	JML. PAX
Wednesday28/	12.01 - 13.00	148	Wednesday28/	12.01 - 13.00	428
Thursday29/	15.01 - 16.00	391	Thursday29/	12.01 - 13.00	335
Friday30/	12.01 - 13.00	145	Friday30/	11.01 - 12.00	163
Saturday31/	14.01 - 15.00	436	Saturday31/	12.01 - 13.00	154

April - 2018

DOMESTIK	TANGGAL	JAM	JML. PAX	TANGGAL	JAM	JML. PAX
	Sunday01/	15.01 - 16.00	2,525	Sunday01/	12.01 - 13.00	1,972
	Monday02/	10.01 - 11.00	2,145	Monday02/	17.01 - 18.00	1,311
	Tuesday03/	14.01 - 15.00	1,827	Tuesday03/	08.01 - 09.00	1,126
	Wednesday04/	15.01 - 16.00	1,961	Wednesday04/	13.01 - 14.00	1,713
	Thursday05/	09.01 - 10.00	2,004	Thursday05/	08.01 - 09.00	1,189
	Friday06/	10.01 - 11.00	2,239	Friday06/	08.01 - 09.00	1,512
	Saturday07/	10.01 - 11.00	2,007	Saturday07/	16.01 - 17.00	1,499
	Sunday08/	10.01 - 11.00	2,272	Sunday08/	13.01 - 14.00	1,568
	Monday09/	10.01 - 11.00	2,362	Monday09/	13.01 - 14.00	1,300
	Tuesday10/	09.01 - 10.00	1,704	Tuesday10/	13.01 - 14.00	1,418
	Wednesday11/	15.01 - 16.00	1,998	Wednesday11/	11.01 - 12.00	1,467
	Thursday12/	10.01 - 11.00	2,163	Thursday12/	14.01 - 15.00	1,326
	Friday13/	10.01 - 11.00	2,317	Friday13/	16.01 - 17.00	1,636
	Saturday14/	10.01 - 11.00	2,157	Saturday14/	12.01 - 13.00	1,828
	Sunday15/	15.01 - 16.00	2,354	Sunday15/	17.01 - 18.00	1,826
	Monday16/	10.01 - 11.00	2,292	Monday16/	12.01 - 13.00	1,596
	Tuesday17/	10.01 - 11.00	1,998	Tuesday17/	14.01 - 15.00	1,370
	Wednesday18/	10.01 - 11.00	2,573	Wednesday18/	08.01 - 09.00	1,678
	Thursday19/	10.01 - 11.00	2,032	Thursday19/	15.01 - 16.00	1,485
	Friday20/	10.01 - 11.00	2,573	Friday20/	13.01 - 14.00	1,342
	Saturday21/	15.01 - 16.00	1,791	Saturday21/	12.01 - 13.00	1,416
	Sunday22/	10.01 - 11.00	1,954	Sunday22/	13.01 - 14.00	1,836
	Monday23/	10.01 - 11.00	2,051	Monday23/	08.01 - 09.00	1,631
	Tuesday24/	14.01 - 15.00	1,916	Tuesday24/	08.01 - 09.00	1,135

	KEBERANGKATAN			KEDATANGAN		
	TANGGAL	JAM	JML. PAX	TANGGAL	JAM	JML. PAX
	Wednesday25/	14.01 - 15.00	1,949	Wednesday25/	13.01 - 14.00	1,486
	Thursday26/	10.01 - 11.00	1,784	Thursday26/	17.01 - 18.00	1,683
	Friday27/	14.01 - 15.00	2,455	Friday27/	08.01 - 09.00	1,667
	Saturday28/	10.01 - 11.00	1,820	Saturday28/	16.01 - 17.00	1,268
	Sunday29/	10.01 - 11.00	2,422	Sunday29/	14.01 - 15.00	1,446
	Monday30/	10.01 - 11.00	1,924	Monday30/	08.01 - 09.00	1,313

INTERNASIONAL

	Sunday01/	11.01 - 12.00	606	Sunday01/	10.01 - 11.00	526
	Monday02/	10.01 - 11.00	399	Monday02/	11.01 - 12.00	161
	Tuesday03/	18.01 - 19.00	125	Tuesday03/	16.01 - 17.00	13
	Wednesday04/	14.01 - 15.00	202	Wednesday04/	20.01 - 21.00	411
	Thursday05/	15.01 - 16.00	446	Thursday05/	12.01 - 13.00	435
	Friday06/	12.01 - 13.00	153	Friday06/	12.01 - 13.00	437
	Saturday07/	08.01 - 09.00	343	Saturday07/	11.01 - 12.00	23
	Sunday08/	15.01 - 16.00	208	Sunday08/	13.01 - 14.00	577
	Monday09/	11.01 - 12.00	148	Monday09/	17.01 - 18.00	144
	Tuesday10/	13.01 - 14.00	128	Tuesday10/	11.01 - 12.00	398
	Wednesday11/	14.01 - 15.00	332	Wednesday11/	12.01 - 13.00	438
	Thursday12/	10.01 - 11.00	405	Thursday12/	12.01 - 13.00	447
	Friday13/	12.01 - 13.00	150	Friday13/	11.01 - 12.00	604
	Saturday14/	08.01 - 09.00	333	Saturday14/	11.01 - 12.00	187
	Sunday15/	19.01 - 20.00	273	Sunday15/	18.01 - 19.00	520
	Monday16/	17.01 - 18.00	169	Monday16/	17.01 - 18.00	145
	Tuesday17/	17.01 - 18.00	392	Tuesday17/	10.01 - 11.00	106
	Wednesday18/	14.01 - 15.00	151	Wednesday18/	11.01 - 12.00	401
	Thursday19/	11.01 - 12.00	421	Thursday19/	12.01 - 13.00	284
	Friday20/	12.01 - 13.00	161	Friday20/	11.01 - 12.00	512
	Saturday21/	08.01 - 09.00	402	Saturday21/	12.01 - 13.00	257
	Sunday22/	14.01 - 15.00	223	Sunday22/	12.01 - 13.00	322
	Monday23/	18.01 - 19.00	159	Monday23/	18.01 - 19.00	150
	Tuesday24/	06.01 - 07.00	345	Tuesday24/	18.01 - 19.00	76
	Wednesday25/	14.01 - 15.00	374	Wednesday25/	09.01 - 10.00	332

	KEBERANGKATAN			KEDATANGAN		
	TANGGAL	JAM	JML. PAX	TANGGAL	JAM	JML. PAX
	Thursday26/	09.01 - 10.00	436	Thursday26/	12.01 - 13.00	244
	Friday27/	12.01 - 13.00	161	Friday27/	12.01 - 13.00	277
	Saturday28/	14.01 - 15.00	378	Saturday28/	12.01 - 13.00	94
	Sunday29/	11.01 - 12.00	152	Sunday29/	09.01 - 10.00	398
	Monday30/	17.01 - 18.00	148	Monday30/	17.01 - 18.00	139

May - 2018

DOMESTIK

Tuesday01/	10.01 - 11.00	2,146	Tuesday01/	16.01 - 17.00	1,384
Wednesday02/	10.01 - 11.00	2,471	Wednesday02/	08.01 - 09.00	1,790
Thursday03/	15.01 - 16.00	2,222	Thursday03/	08.01 - 09.00	1,714
Friday04/	16.01 - 17.00	2,258	Friday04/	12.01 - 13.00	1,825
Saturday05/	15.01 - 16.00	2,451	Saturday05/	13.01 - 14.00	1,446
Sunday06/	10.01 - 11.00	2,613	Sunday06/	11.01 - 12.00	1,507
Monday07/	10.01 - 11.00	2,458	Monday07/	08.01 - 09.00	1,590
Tuesday08/	16.01 - 17.00	1,898	Tuesday08/	08.01 - 09.00	1,623
Wednesday09/	15.01 - 16.00	2,580	Wednesday09/	16.01 - 17.00	1,699
Thursday10/	14.01 - 15.00	2,077	Thursday10/	12.01 - 13.00	2,127
Friday11/	14.01 - 15.00	2,082	Friday11/	08.01 - 09.00	1,629
Saturday12/	10.01 - 11.00	2,341	Saturday12/	16.01 - 17.00	1,391
Sunday13/	14.01 - 15.00	2,214	Sunday13/	12.01 - 13.00	1,723
Monday14/	10.01 - 11.00	2,669	Monday14/	08.01 - 09.00	1,615
Tuesday15/	14.01 - 15.00	1,753	Tuesday15/	11.01 - 12.00	1,288
Wednesday16/	15.01 - 16.00	1,793	Wednesday16/	11.01 - 12.00	1,360
Thursday17/	14.01 - 15.00	1,251	Thursday17/	16.01 - 17.00	1,183
Friday18/	13.01 - 14.00	1,366	Friday18/	16.01 - 17.00	1,461
Saturday19/	16.01 - 17.00	1,431	Saturday19/	14.01 - 15.00	1,215
Sunday20/	14.01 - 15.00	1,901	Sunday20/	12.01 - 13.00	1,297
Monday21/	14.01 - 15.00	1,450	Monday21/	11.01 - 12.00	1,208
Tuesday22/	13.01 - 14.00	1,537	Tuesday22/	12.01 - 13.00	1,180
Wednesday23/	14.01 - 15.00	1,773	Wednesday23/	16.01 - 17.00	1,582
Thursday24/	15.01 - 16.00	1,528	Thursday24/	12.01 - 13.00	1,334

	KEBERANGKATAN			KEDATANGAN		
	TANGGAL	JAM	JML. PAX	TANGGAL	JAM	JML. PAX
	Friday25/	10.01 - 11.00	1,490	Friday25/	16.01 - 17.00	1,417
	Saturday26/	14.01 - 15.00	1,632	Saturday26/	13.01 - 14.00	1,188
	Sunday27/	14.01 - 15.00	1,792	Sunday27/	11.01 - 12.00	1,459
	Monday28/	10.01 - 11.00	1,251	Monday28/	16.01 - 17.00	1,220
	Tuesday29/	15.01 - 16.00	1,869	Tuesday29/	12.01 - 13.00	1,495
	Wednesday30/	10.01 - 11.00	1,676	Wednesday30/	12.01 - 13.00	1,944
	Thursday31/	15.01 - 16.00	1,605	Thursday31/	16.01 - 17.00	1,609
INTERNASIONAL	Tuesday01/	19.01 - 20.00	75	Tuesday01/	18.01 - 19.00	44
	Wednesday02/	12.01 - 13.00	161	Wednesday02/	10.01 - 11.00	402
	Thursday03/	10.01 - 11.00	276	Thursday03/	13.01 - 14.00	310
	Friday04/	12.01 - 13.00	149	Friday04/	11.01 - 12.00	864
	Saturday05/	08.01 - 09.00	297	Saturday05/	12.01 - 13.00	285
	Sunday06/	11.01 - 12.00	170	Sunday06/	13.01 - 14.00	436
	Monday07/	18.01 - 19.00	155	Monday07/	17.01 - 18.00	140
	Tuesday08/	19.01 - 20.00	99	Tuesday08/	18.01 - 19.00	100
	Wednesday09/	12.01 - 13.00	164	Wednesday09/	09.01 - 10.00	377
	Thursday10/	09.01 - 10.00	279	Thursday10/	10.01 - 11.00	139
	Friday11/	12.01 - 13.00	145	Friday11/	12.01 - 13.00	409
	Saturday12/	14.01 - 15.00	209	Saturday12/	11.01 - 12.00	45
	Sunday13/	11.01 - 12.00	152	Sunday13/	16.01 - 17.00	210
	Monday14/	12.01 - 13.00	191	Monday14/	16.01 - 17.00	137
	Tuesday15/	19.01 - 20.00	48	Tuesday15/	18.01 - 19.00	61
	Wednesday16/	14.01 - 15.00	174	Wednesday16/	09.01 - 10.00	298
	Thursday17/	07.01 - 08.00	163	Thursday17/	10.01 - 11.00	66
	Friday18/	12.01 - 13.00	131	Friday18/	11.01 - 12.00	456
	Saturday19/	14.01 - 15.00	210	Saturday19/	12.01 - 13.00	81
	Sunday20/	11.01 - 12.00	141	Sunday20/	12.01 - 13.00	165
	Monday21/	18.01 - 19.00	107	Monday21/	17.01 - 18.00	134
	Tuesday22/	19.01 - 20.00	30	Tuesday22/	18.01 - 19.00	83
	Wednesday23/	12.01 - 13.00	106	Wednesday23/	13.01 - 14.00	222
	Thursday24/	11.01 - 12.00	107	Thursday24/	12.01 - 13.00	154

	KEBERANGKATAN			KEDATANGAN		
	TANGGAL	JAM	JML. PAX	TANGGAL	JAM	JML. PAX
	Friday25/	12.01 - 13.00	110	Friday25/	12.01 - 13.00	281
	Sunday27/	11.01 - 12.00	126	Sunday27/	12.01 - 13.00	217
	Monday28/	18.01 - 19.00	45	Monday28/	17.01 - 18.00	99
	Tuesday29/	19.01 - 20.00	52	Tuesday29/	18.01 - 19.00	59
	Wednesday30/	12.01 - 13.00	138	Wednesday30/	16.01 - 17.00	158
	Thursday31/	07.01 - 08.00	277	Thursday31/	10.01 - 11.00	75

June - 2018

DOMESTIK

Friday01/	15.01 - 16.00	1,664	Friday01/	11.01 - 12.00	1,741
Saturday02/	15.01 - 16.00	1,639	Saturday02/	13.01 - 14.00	1,395
Sunday03/	15.01 - 16.00	2,387	Sunday03/	12.01 - 13.00	1,517
Monday04/	15.01 - 16.00	1,952	Monday04/	08.01 - 09.00	1,497
Tuesday05/	15.01 - 16.00	1,856	Tuesday05/	13.01 - 14.00	1,390
Wednesday06/	10.01 - 11.00	2,254	Wednesday06/	14.01 - 15.00	1,665
Thursday07/	16.01 - 17.00	2,084	Thursday07/	08.01 - 09.00	1,521
Friday08/	10.01 - 11.00	2,021	Friday08/	08.01 - 09.00	1,571
Saturday09/	10.01 - 11.00	1,907	Saturday09/	14.01 - 15.00	2,005
Sunday10/	15.01 - 16.00	2,087	Sunday10/	11.01 - 12.00	1,588
Monday11/	15.01 - 16.00	2,729	Monday11/	09.01 - 10.00	1,700
Tuesday12/	15.01 - 16.00	1,941	Tuesday12/	12.01 - 13.00	2,014
Wednesday13/	15.01 - 16.00	1,715	Wednesday13/	12.01 - 13.00	1,816
Thursday14/	10.01 - 11.00	1,647	Thursday14/	13.01 - 14.00	1,481
Friday15/	15.01 - 16.00	1,870	Friday15/	12.01 - 13.00	1,704
Saturday16/	15.01 - 16.00	1,817	Saturday16/	12.01 - 13.00	1,628
Sunday17/	15.01 - 16.00	2,029	Sunday17/	13.01 - 14.00	1,966
Monday18/	10.01 - 11.00	2,547	Monday18/	12.01 - 13.00	1,506
Tuesday19/	14.01 - 15.00	2,854	Tuesday19/	12.01 - 13.00	1,603
Wednesday20/	10.01 - 11.00	2,286	Wednesday20/	13.01 - 14.00	1,827
Thursday21/	16.01 - 17.00	2,363	Thursday21/	08.01 - 09.00	1,725
Friday22/	15.01 - 16.00	2,548	Friday22/	08.01 - 09.00	1,584

	KEBERANGKATAN			KEDATANGAN		
	TANGGAL	JAM	JML. PAX	TANGGAL	JAM	JML. PAX
	Saturday23/	15.01 - 16.00	2,339	Saturday23/	12.01 - 13.00	1,615
	Sunday24/	10.01 - 11.00	2,554	Sunday24/	17.01 - 18.00	1,896
	Monday25/	10.01 - 11.00	2,013	Monday25/	09.01 - 10.00	1,640
	Tuesday26/	15.01 - 16.00	2,374	Tuesday26/	08.01 - 09.00	1,714
	Wednesday27/	10.01 - 11.00	2,614	Wednesday27/	12.01 - 13.00	1,473
	Thursday28/	14.01 - 15.00	2,242	Thursday28/	13.01 - 14.00	1,766
	Friday29/	10.01 - 11.00	2,221	Friday29/	12.01 - 13.00	1,444
	Saturday30/	10.01 - 11.00	2,522	Saturday30/	12.01 - 13.00	1,425
INTERNASIONAL	Friday01/	12.01 - 13.00	131	Friday01/	11.01 - 12.00	157
	Sunday03/	11.01 - 12.00	117	Sunday03/	10.01 - 11.00	158
	Monday04/	18.01 - 19.00	127	Monday04/	17.01 - 18.00	155
	Tuesday05/	19.01 - 20.00	76	Tuesday05/	18.01 - 19.00	80
	Wednesday06/	12.01 - 13.00	141	Wednesday06/	11.01 - 12.00	186
	Thursday07/	12.01 - 13.00	144	Thursday07/	11.01 - 12.00	84
	Friday08/	12.01 - 13.00	161	Friday08/	11.01 - 12.00	180
	Sunday10/	12.01 - 13.00	162	Sunday10/	11.01 - 12.00	178
	Monday11/	17.01 - 18.00	169	Monday11/	17.01 - 18.00	180
	Tuesday12/	19.01 - 20.00	109	Tuesday12/	18.01 - 19.00	46
	Wednesday13/	12.01 - 13.00	173	Wednesday13/	11.01 - 12.00	170
	Thursday14/	11.01 - 12.00	152	Thursday14/	10.01 - 11.00	112
	Friday15/	12.01 - 13.00	160	Friday15/	11.01 - 12.00	156
	Sunday17/	11.01 - 12.00	155	Sunday17/	10.01 - 11.00	170
	Monday18/	18.01 - 19.00	161	Monday18/	17.01 - 18.00	159
	Tuesday19/	19.01 - 20.00	71	Tuesday19/	18.01 - 19.00	140
	Wednesday20/	12.01 - 13.00	146	Wednesday20/	11.01 - 12.00	168
	Thursday21/	12.01 - 13.00	68	Thursday21/	11.01 - 12.00	142
	Friday22/	12.01 - 13.00	145	Friday22/	11.01 - 12.00	172
	Sunday24/	11.01 - 12.00	158	Sunday24/	10.01 - 11.00	167
	Monday25/	20.01 - 21.00	151	Monday25/	19.01 - 20.00	161
	Tuesday26/	19.01 - 20.00	132	Tuesday26/	18.01 - 19.00	136
	Wednesday27/	12.01 - 13.00	157	Wednesday27/	11.01 - 12.00	170

	KEBERANGKATAN			KEDATANGAN		
	TANGGAL	JAM	JML. PAX	TANGGAL	JAM	JML. PAX
	Thursday28/	12.01 - 13.00	121	Thursday28/	10.01 - 11.00	61
	Friday29/	12.01 - 13.00	155	Friday29/	11.01 - 12.00	144

July - 2018

DOMESTIK

Sunday01/	10.01 - 11.00	2,510	Sunday01/	13.01 - 14.00	1,984
Monday02/	14.01 - 15.00	2,075	Monday02/	09.01 - 10.00	1,522
Tuesday03/	17.01 - 18.00	2,087	Tuesday03/	08.01 - 09.00	1,537
Wednesday04/	16.01 - 17.00	2,436	Wednesday04/	09.01 - 10.00	1,772
Thursday05/	10.01 - 11.00	2,819	Thursday05/	14.01 - 15.00	1,655
Friday06/	15.01 - 16.00	2,657	Friday06/	13.01 - 14.00	1,740
Saturday07/	10.01 - 11.00	2,585	Saturday07/	14.01 - 15.00	1,680
Sunday08/	10.01 - 11.00	3,051	Sunday08/	07.01 - 08.00	1,492
Monday09/	10.01 - 11.00	2,328	Monday09/	13.01 - 14.00	1,705
Tuesday10/	10.01 - 11.00	2,455	Tuesday10/	14.01 - 15.00	1,545
Wednesday11/	06.01 - 07.00	2,403	Wednesday11/	11.01 - 12.00	1,692
Thursday12/	10.01 - 11.00	2,682	Thursday12/	14.01 - 15.00	1,624
Friday13/	11.01 - 12.00	2,180	Friday13/	09.01 - 10.00	1,485
Saturday14/	10.01 - 11.00	2,068	Saturday14/	12.01 - 13.00	1,611
Sunday15/	10.01 - 11.00	2,640	Sunday15/	12.01 - 13.00	1,677
Monday16/	10.01 - 11.00	2,216	Monday16/	16.01 - 17.00	1,653
Tuesday17/	10.01 - 11.00	1,813	Tuesday17/	17.01 - 18.00	1,388
Wednesday18/	15.01 - 16.00	2,315	Wednesday18/	13.01 - 14.00	1,688
Thursday19/	10.01 - 11.00	2,423	Thursday19/	11.01 - 12.00	1,456
Friday20/	10.01 - 11.00	2,189	Friday20/	11.01 - 12.00	1,746
Saturday21/	15.01 - 16.00	1,868	Saturday21/	09.01 - 10.00	1,449
Sunday22/	10.01 - 11.00	2,636	Sunday22/	09.01 - 10.00	1,679
Monday23/	10.01 - 11.00	2,383	Monday23/	09.01 - 10.00	1,432
Tuesday24/	16.01 - 17.00	1,825	Tuesday24/	11.01 - 12.00	1,536
Wednesday25/	10.01 - 11.00	2,593	Wednesday25/	12.01 - 13.00	1,845

	KEBERANGKATAN			KEDATANGAN		
	TANGGAL	JAM	JML. PAX	TANGGAL	JAM	JML. PAX
	Thursday26/	10.01 - 11.00	2,292	Thursday26/	08.01 - 09.00	1,574
	Friday27/	10.01 - 11.00	2,403	Friday27/	16.01 - 17.00	1,369
	Saturday28/	10.01 - 11.00	2,051	Saturday28/	12.01 - 13.00	1,402
	Sunday29/	16.01 - 17.00	2,781	Sunday29/	18.01 - 19.00	1,388
	Monday30/	10.01 - 11.00	2,279	Monday30/	20.01 - 21.00	1,294
	Tuesday31/	10.01 - 11.00	2,083	Tuesday31/	11.01 - 12.00	1,308
INTERNASIONAL	Sunday01/	11.01 - 12.00	161	Sunday01/	11.01 - 12.00	159
	Monday02/	17.01 - 18.00	168	Monday02/	16.01 - 17.00	172
	Wednesday04/	13.01 - 14.00	165	Wednesday04/	11.01 - 12.00	177
	Thursday05/	12.01 - 13.00	89	Thursday05/	10.01 - 11.00	145
	Friday06/	12.01 - 13.00	159	Friday06/	11.01 - 12.00	169
	Sunday08/	11.01 - 12.00	161	Sunday08/	10.01 - 11.00	168
	Monday09/	17.01 - 18.00	159	Monday09/	16.01 - 17.00	168
	Wednesday11/	12.01 - 13.00	169	Wednesday11/	11.01 - 12.00	151
	Thursday12/	12.01 - 13.00	111	Thursday12/	10.01 - 11.00	138
	Friday13/	11.01 - 12.00	159	Friday13/	11.01 - 12.00	150
	Sunday15/	11.01 - 12.00	159	Sunday15/	10.01 - 11.00	161
	Monday16/	17.01 - 18.00	154	Monday16/	17.01 - 18.00	160
	Tuesday17/	17.01 - 18.00	453	Tuesday17/	-	
	Wednesday18/	09.01 - 10.00	454	Wednesday18/	11.01 - 12.00	157
	Thursday19/	01.01 - 02.00	455	Thursday19/	11.01 - 12.00	138
	Friday20/	07.01 - 08.00	455	Friday20/	11.01 - 12.00	149
	Saturday21/	22.01 - 23.00	455	Saturday21/	-	
	Sunday22/	20.01 - 21.00	455	Sunday22/	11.01 - 12.00	131
	Monday23/	01.01 - 02.00	450	Monday23/	17.01 - 18.00	142
	Tuesday24/	17.01 - 18.00	453			
	Wednesday25/	11.01 - 12.00	448	Wednesday25/	11.01 - 12.00	140
	Thursday26/	03.01 - 04.00	454	Thursday26/	10.01 - 11.00	99
	Friday27/	15.01 - 16.00	146	Friday27/	11.01 - 12.00	151
	Saturday28/	01.01 - 02.00	452			
	Sunday29/	12.01 - 13.00	454	Sunday29/	10.01 - 11.00	142

	KEBERANGKATAN			KEDATANGAN		
	TANGGAL	JAM	JML. PAX	TANGGAL	JAM	JML. PAX
	Monday30/	22.01 - 23.00	455	Monday30/	17.01 - 18.00	141

August - 2018

DOMESTIK

Wednesday01/	15.01 - 16.00	2,042	Wednesday01/	12.01 - 13.00	1,564
Thursday02/	15.01 - 16.00	1,755	Thursday02/	14.01 - 15.00	1,367
Friday03/	10.01 - 11.00	2,192	Friday03/	07.01 - 08.00	1,301
Saturday04/	10.01 - 11.00	2,193	Saturday04/	14.01 - 15.00	1,588
Sunday05/	10.01 - 11.00	2,239	Sunday05/	08.01 - 09.00	1,516
Monday06/	15.01 - 16.00	1,875	Monday06/	08.01 - 09.00	1,349
Tuesday07/	16.01 - 17.00	1,555	Tuesday07/	08.01 - 09.00	1,494
Wednesday08/	14.01 - 15.00	1,947	Wednesday08/	13.01 - 14.00	1,851
Thursday09/	10.01 - 11.00	2,230	Thursday09/	08.01 - 09.00	1,542
Friday10/	10.01 - 11.00	2,115	Friday10/	09.01 - 10.00	1,381
Saturday11/	16.01 - 17.00	1,930	Saturday11/	08.01 - 09.00	1,344
Sunday12/	10.01 - 11.00	2,292	Sunday12/	12.01 - 13.00	1,287
Monday13/	10.01 - 11.00	2,139	Monday13/	09.01 - 10.00	1,511
Tuesday14/	10.01 - 11.00	2,192	Tuesday14/	12.01 - 13.00	1,809
Wednesday15/	10.01 - 11.00	2,350	Wednesday15/	17.01 - 18.00	1,673
Thursday16/	10.01 - 11.00	2,060	Thursday16/	12.01 - 13.00	1,874
Friday17/	10.01 - 11.00	2,244	Friday17/	12.01 - 13.00	1,501
Saturday18/	15.01 - 16.00	1,676	Saturday18/	08.01 - 09.00	1,436
Sunday19/	16.01 - 17.00	1,827	Sunday19/	11.01 - 12.00	1,696
Monday20/	10.01 - 11.00	1,583	Monday20/	12.01 - 13.00	1,413
Tuesday21/	16.01 - 17.00	1,524	Tuesday21/	12.01 - 13.00	1,500
Wednesday22/	13.01 - 14.00	1,300	Wednesday22/	12.01 - 13.00	1,205
Thursday23/	14.01 - 15.00	1,553	Thursday23/	08.01 - 09.00	1,513
Friday24/	10.01 - 11.00	1,861	Friday24/	12.01 - 13.00	1,285
Saturday25/	10.01 - 11.00	2,168	Saturday25/	08.01 - 09.00	1,526
Sunday26/	10.01 - 11.00	2,638	Sunday26/	14.01 - 15.00	1,709
Monday27/	10.01 - 11.00	2,598	Monday27/	14.01 - 15.00	1,683
Tuesday28/	10.01 - 11.00	2,213	Tuesday28/	14.01 - 15.00	1,758

	KEBERANGKATAN			KEDATANGAN		
	TANGGAL	JAM	JML. PAX	TANGGAL	JAM	JML. PAX
	Wednesday29/	10.01 - 11.00	2,806	Wednesday29/	11.01 - 12.00	1,802
	Thursday30/	10.01 - 11.00	2,441	Thursday30/	11.01 - 12.00	1,704
	Friday31/	10.01 - 11.00	3,296	Friday31/	12.01 - 13.00	1,716
INTERNASIONAL	Wednesday01/	13.01 - 14.00	141	Wednesday01/	11.01 - 12.00	137
	Thursday02/	00.01 - 01.00	454	Thursday02/	10.01 - 11.00	83
	Friday03/	07.01 - 08.00	455	Friday03/	11.01 - 12.00	160
	Saturday04/	01.01 - 02.00	454	Saturday04/	-	
	Sunday05/	14.01 - 15.00	452	Sunday05/	10.01 - 11.00	147
	Monday06/	21.01 - 22.00	453	Monday06/	10.01 - 11.00	144
	Tuesday07/	19.01 - 20.00	453	Tuesday07/	-	
	Wednesday08/	08.01 - 09.00	454	Wednesday08/	11.01 - 12.00	147
	Thursday09/	06.01 - 07.00	455	Thursday09/	11.01 - 12.00	99
	Friday10/	18.01 - 19.00	455	Friday10/	11.01 - 12.00	173
	Saturday11/	11.01 - 12.00	455	Saturday11/	-	
	Sunday12/	08.01 - 09.00	455	Sunday12/	11.01 - 12.00	163
	Monday13/	19.01 - 20.00	600	Monday13/	18.01 - 19.00	168
	Tuesday14/	08.01 - 09.00	441	Tuesday14/	-	
	Wednesday15/	12.01 - 13.00	146	Wednesday15/	11.01 - 12.00	164
	Thursday16/	11.01 - 12.00	150	Thursday16/	10.01 - 11.00	98
	Friday17/	12.01 - 13.00	127	Friday17/	11.01 - 12.00	176
	Sunday19/	11.01 - 12.00	146	Sunday19/	10.01 - 11.00	163
	Monday20/	17.01 - 18.00	132	Monday20/	16.01 - 17.00	165
	Tuesday21/	19.01 - 20.00	2			
	Wednesday22/	11.01 - 12.00	141	Wednesday22/	11.01 - 12.00	155
	Thursday23/	11.01 - 12.00	132	Thursday23/	10.01 - 11.00	101
	Friday24/	12.01 - 13.00	135	Friday24/	11.01 - 12.00	161
	Sunday26/	11.01 - 12.00	154	Sunday26/	10.01 - 11.00	150
	Monday27/	17.01 - 18.00	140	Monday27/	16.01 - 17.00	149
	Tuesday28/	21.01 - 22.00	105	Tuesday28/	16.01 - 17.00	452
	Wednesday29/	12.01 - 13.00	160	Wednesday29/	12.01 - 13.00	455
	Thursday30/	-		Thursday30/	02.01 - 03.00	455

	KEBERANGKATAN			KEDATANGAN		
	TANGGAL	JAM	JML. PAX	TANGGAL	JAM	JML. PAX
	Friday31/	12.01 - 13.00	167	Friday31/	09.01 - 10.00	455

September - 2018

DOMESTIK	TANGGAL	JAM	JML. PAX	TANGGAL	JAM	JML. PAX
	Saturday01/	10.01 - 11.00	2,725	Saturday01/	09.01 - 10.00	1,578
	Sunday02/	10.01 - 11.00	2,288	Sunday02/	08.01 - 09.00	1,632
	Monday03/	10.01 - 11.00	2,799	Monday03/	08.01 - 09.00	1,636
	Tuesday04/	10.01 - 11.00	1,886	Tuesday04/	08.01 - 09.00	1,653
	Wednesday05/	10.01 - 11.00	2,893	Wednesday05/	12.01 - 13.00	1,654
	Thursday06/	10.01 - 11.00	2,173	Thursday06/	17.01 - 18.00	1,920
	Friday07/	10.01 - 11.00	2,343	Friday07/	08.01 - 09.00	2,099
	Saturday08/	10.01 - 11.00	2,433	Saturday08/	14.01 - 15.00	1,776
	Sunday09/	15.01 - 16.00	2,580	Sunday09/	12.01 - 13.00	1,836
	Monday10/	10.01 - 11.00	1,853	Monday10/	08.01 - 09.00	1,280
	Tuesday11/	15.01 - 16.00	2,231	Tuesday11/	13.01 - 14.00	1,686
	Wednesday12/	10.01 - 11.00	2,449	Wednesday12/	12.01 - 13.00	1,619
	Thursday13/	10.01 - 11.00	1,815	Thursday13/	14.01 - 15.00	1,424
	Friday14/	10.01 - 11.00	2,024	Friday14/	18.01 - 19.00	1,503
	Saturday15/	10.01 - 11.00	2,094	Saturday15/	13.01 - 14.00	1,338
	Sunday16/	10.01 - 11.00	2,235	Sunday16/	12.01 - 13.00	1,745
	Monday17/	10.01 - 11.00	1,918	Monday17/	14.01 - 15.00	1,730
	Tuesday18/	15.01 - 16.00	1,658	Tuesday18/	16.01 - 17.00	1,199
	Wednesday19/	10.01 - 11.00	2,076	Wednesday19/	08.01 - 09.00	1,696
	Thursday20/	10.01 - 11.00	1,867	Thursday20/	08.01 - 09.00	1,534
	Friday21/	10.01 - 11.00	2,270	Friday21/	13.01 - 14.00	1,513
	Saturday22/	10.01 - 11.00	2,235	Saturday22/	09.01 - 10.00	1,355
	Sunday23/	10.01 - 11.00	2,141	Sunday23/	08.01 - 09.00	1,620
	Monday24/	10.01 - 11.00	1,687	Monday24/	11.01 - 12.00	1,333
	Tuesday25/	10.01 - 11.00	1,692	Tuesday25/	08.01 - 09.00	1,385
	Wednesday26/	10.01 - 11.00	2,120	Wednesday26/	11.01 - 12.00	1,356
	Thursday27/	15.01 - 16.00	1,780	Thursday27/	08.01 - 09.00	1,525

	KEBERANGKATAN			KEDATANGAN		
	TANGGAL	JAM	JML. PAX	TANGGAL	JAM	JML. PAX
	Friday28/	10.01 - 11.00	1,931	Friday28/	14.01 - 15.00	1,297
	Saturday29/	10.01 - 11.00	1,426	Saturday29/	12.01 - 13.00	1,481
	Sunday30/	10.01 - 11.00	1,969	Sunday30/	13.01 - 14.00	1,633
INTERNASIONAL	Saturday01/	-		Saturday01/	06.01 - 07.00	453
	Sunday02/	11.01 - 12.00	165	Sunday02/	00.01 - 01.00	454
	Monday03/	19.01 - 20.00	147	Monday03/	05.01 - 06.00	453
	Tuesday04/	-		Tuesday04/	02.01 - 03.00	455
	Wednesday05/	13.01 - 14.00	161	Wednesday05/	11.01 - 12.00	447
	Thursday06/	11.01 - 12.00	127	Thursday06/	06.01 - 07.00	452
	Friday07/	12.01 - 13.00	166	Friday07/	11.01 - 12.00	152
	Saturday08/	-		Saturday08/	06.01 - 07.00	452
	Sunday09/	11.01 - 12.00	162	Sunday09/	11.01 - 12.00	452
	Monday10/	18.01 - 19.00	156	Monday10/	22.01 - 23.00	455
	Wednesday12/	12.01 - 13.00	170	Wednesday12/	23.01 - 24.00	453
	Thursday13/	11.01 - 12.00	124	Thursday13/	16.01 - 17.00	452
	Friday14/	12.01 - 13.00	151	Friday14/	15.01 - 16.00	454
	Saturday15/	-		Saturday15/	22.01 - 23.00	455
	Sunday16/	11.01 - 12.00	141	Sunday16/	11.01 - 12.00	455
	Monday17/	18.01 - 19.00	125	Monday17/	08.01 - 09.00	454
	Tuesday18/	-		Tuesday18/	17.01 - 18.00	451
	Wednesday19/	12.01 - 13.00	149	Wednesday19/	07.01 - 08.00	454
	Thursday20/	11.01 - 12.00	110	Thursday20/	06.01 - 07.00	452
	Friday21/	12.01 - 13.00	159	Friday21/	01.01 - 02.00	453
	Saturday22/	-		Saturday22/	11.01 - 12.00	455
	Sunday23/	11.01 - 12.00	174	Sunday23/	11.01 - 12.00	454
	Monday24/	17.01 - 18.00	161	Monday24/	04.01 - 05.00	453
	Tuesday25/	-		Tuesday25/	11.01 - 12.00	437
	Wednesday26/	12.01 - 13.00	161	Wednesday26/	11.01 - 12.00	135
	Thursday27/	11.01 - 12.00	122	Thursday27/	10.01 - 11.00	126
	Friday28/	12.01 - 13.00	165	Friday28/	11.01 - 12.00	166
	Sunday30/	11.01 - 12.00	145	Sunday30/	10.01 - 11.00	122

	KEBERANGKATAN			KEDATANGAN		
	TANGGAL	JAM	JML. PAX	TANGGAL	JAM	JML. PAX
October - 2018						
DOMESTIK	Monday01/	10.01 - 11.00	1,858	Monday01/	16.01 - 17.00	1,637
	Tuesday02/	10.01 - 11.00	1,588	Tuesday02/	11.01 - 12.00	1,447
	Wednesday03/	10.01 - 11.00	1,999	Wednesday03/	13.01 - 14.00	1,440
	Thursday04/	10.01 - 11.00	1,828	Thursday04/	16.01 - 17.00	1,458
	Friday05/	10.01 - 11.00	2,554	Friday05/	12.01 - 13.00	1,590
	Saturday06/	10.01 - 11.00	1,993	Saturday06/	14.01 - 15.00	1,624
	Sunday07/	10.01 - 11.00	2,368	Sunday07/	14.01 - 15.00	1,742
	Monday08/	10.01 - 11.00	2,423	Monday08/	09.01 - 10.00	1,594
	Tuesday09/	14.01 - 15.00	2,049	Tuesday09/	08.01 - 09.00	1,603
	Wednesday10/	10.01 - 11.00	2,499	Wednesday10/	11.01 - 12.00	1,518
	Thursday11/	10.01 - 11.00	2,644	Thursday11/	09.01 - 10.00	1,487
	Friday12/	10.01 - 11.00	2,657	Friday12/	08.01 - 09.00	1,460
	Saturday13/	10.01 - 11.00	2,382	Saturday13/	13.01 - 14.00	1,543
	Sunday14/	15.01 - 16.00	2,442	Sunday14/	13.01 - 14.00	1,575
	Monday15/	10.01 - 11.00	2,574	Monday15/	09.01 - 10.00	1,568
	Tuesday16/	10.01 - 11.00	2,453	Tuesday16/	13.01 - 14.00	1,452
	Wednesday17/	10.01 - 11.00	2,495	Wednesday17/	09.01 - 10.00	1,584
	Thursday18/	10.01 - 11.00	2,342	Thursday18/	14.01 - 15.00	1,427
	Friday19/	10.01 - 11.00	2,525	Friday19/	14.01 - 15.00	1,590
	Saturday20/	10.01 - 11.00	2,853	Saturday20/	07.01 - 08.00	1,455
	Sunday21/	10.01 - 11.00	2,261	Sunday21/	09.01 - 10.00	1,565
	Monday22/	14.01 - 15.00	2,029	Monday22/	09.01 - 10.00	1,594
	Tuesday23/	10.01 - 11.00	2,188	Tuesday23/	08.01 - 09.00	1,611
	Wednesday24/	10.01 - 11.00	2,687	Wednesday24/	09.01 - 10.00	1,555
	Thursday25/	10.01 - 11.00	1,938	Thursday25/	14.01 - 15.00	1,497
	Friday26/	15.01 - 16.00	2,778	Friday26/	08.01 - 09.00	1,551
	Saturday27/	10.01 - 11.00	2,597	Saturday27/	11.01 - 12.00	1,473
	Sunday28/	10.01 - 11.00	2,603	Sunday28/	14.01 - 15.00	1,836

	KEBERANGKATAN			KEDATANGAN		
	TANGGAL	JAM	JML. PAX	TANGGAL	JAM	JML. PAX
	Monday29/	10.01 - 11.00	2,287	Monday29/	08.01 - 09.00	1,410
	Tuesday30/	10.01 - 11.00	1,667	Tuesday30/	07.01 - 08.00	1,461
	Wednesday31/	15.01 - 16.00	2,123	Wednesday31/	07.01 - 08.00	1,413
INTERNASIONAL	Monday01/	19.01 - 20.00	154	Monday01/	18.01 - 19.00	143
	Wednesday03/	11.01 - 12.00	132	Wednesday03/	11.01 - 12.00	141
	Thursday04/	12.01 - 13.00	136	Thursday04/	10.01 - 11.00	115
	Friday05/	11.01 - 12.00	158	Friday05/	11.01 - 12.00	143
	Sunday07/	11.01 - 12.00	165	Sunday07/	11.01 - 12.00	145
	Monday08/	17.01 - 18.00	145	Monday08/	16.01 - 17.00	151
	Wednesday10/	12.01 - 13.00	159	Wednesday10/	11.01 - 12.00	169
	Thursday11/	12.01 - 13.00	128	Thursday11/	10.01 - 11.00	128
	Friday12/	12.01 - 13.00	156	Friday12/	11.01 - 12.00	167
	Sunday14/	11.01 - 12.00	170	Sunday14/	18.01 - 19.00	144
	Monday15/	07.01 - 08.00	419	Monday15/	18.01 - 19.00	160
	Tuesday16/	12.01 - 13.00	415	Tuesday16/	-	
	Wednesday17/	12.01 - 13.00	152	Wednesday17/	11.01 - 12.00	153
	Thursday18/	06.01 - 07.00	414	Thursday18/	10.01 - 11.00	137
	Friday19/	12.01 - 13.00	160	Friday19/	11.01 - 12.00	164
	Saturday20/	12.01 - 13.00	175	Saturday20/	-	
	Sunday21/	12.01 - 13.00	163	Sunday21/	11.01 - 12.00	162
	Monday22/	08.01 - 09.00	419	Monday22/	17.01 - 18.00	159
	Tuesday23/	12.01 - 13.00	421			
	Wednesday24/	07.01 - 08.00	415	Wednesday24/	14.01 - 15.00	415
	Thursday25/	06.01 - 07.00	414	Thursday25/	11.01 - 12.00	82
	Friday26/	12.01 - 13.00	155	Friday26/	10.01 - 11.00	418
	Sunday28/	19.01 - 20.00	203	Sunday28/	18.01 - 19.00	248
	Monday29/	08.01 - 09.00	427	Monday29/	16.01 - 17.00	166
	Tuesday30/	12.01 - 13.00	400	Tuesday30/	09.01 - 10.00	416
	Wednesday31/	09.01 - 10.00	417	Wednesday31/	14.01 - 15.00	420

	KEBERANGKATAN			KEDATANGAN		
	TANGGAL	JAM	JML. PAX	TANGGAL	JAM	JML. PAX
DOMESTIK	Thursday01/	10.01 - 11.00	2,240	Thursday01/	07.01 - 08.00	1,583
	Friday02/	10.01 - 11.00	2,243	Friday02/	07.01 - 08.00	1,437
	Saturday03/	10.01 - 11.00	2,277	Saturday03/	09.01 - 10.00	1,458
	Sunday04/	10.01 - 11.00	2,117	Sunday04/	13.01 - 14.00	1,698
	Monday05/	10.01 - 11.00	2,106	Monday05/	07.01 - 08.00	1,296
	Tuesday06/	10.01 - 11.00	1,518	Tuesday06/	14.01 - 15.00	1,321
	Wednesday07/	10.01 - 11.00	1,900	Wednesday07/	08.01 - 09.00	1,638
	Thursday08/	15.01 - 16.00	2,363	Thursday08/	13.01 - 14.00	1,633
	Friday09/	10.01 - 11.00	2,324	Friday09/	08.01 - 09.00	1,278
	Saturday10/	10.01 - 11.00	2,014	Saturday10/	07.01 - 08.00	1,352
	Sunday11/	10.01 - 11.00	2,287	Sunday11/	13.01 - 14.00	1,483
	Monday12/	10.01 - 11.00	1,754	Monday12/	08.01 - 09.00	1,341
	Tuesday13/	10.01 - 11.00	1,665	Tuesday13/	14.01 - 15.00	1,416
	Wednesday14/	10.01 - 11.00	2,327	Wednesday14/	14.01 - 15.00	1,487
	Thursday15/	10.01 - 11.00	1,986	Thursday15/	14.01 - 15.00	1,608
	Friday16/	10.01 - 11.00	2,449	Friday16/	08.01 - 09.00	1,432
	Saturday17/	10.01 - 11.00	2,098	Saturday17/	07.01 - 08.00	1,642
	Sunday18/	10.01 - 11.00	1,885	Sunday18/	13.01 - 14.00	1,463
	Monday19/	10.01 - 11.00	1,877	Monday19/	08.01 - 09.00	1,201
	Tuesday20/	15.01 - 16.00	2,830	Tuesday20/	13.01 - 14.00	1,745
	Wednesday21/	10.01 - 11.00	2,005	Wednesday21/	07.01 - 08.00	1,526
	Thursday22/	10.01 - 11.00	1,504	Thursday22/	16.01 - 17.00	1,303
	Friday23/	10.01 - 11.00	2,299	Friday23/	13.01 - 14.00	1,280
	Saturday24/	14.01 - 15.00	1,621	Saturday24/	12.01 - 13.00	1,421
	Sunday25/	10.01 - 11.00	1,908	Sunday25/	16.01 - 17.00	1,452
	Monday26/	10.01 - 11.00	2,200	Monday26/	08.01 - 09.00	1,623
	Tuesday27/	14.01 - 15.00	1,925	Tuesday27/	07.01 - 08.00	1,277
	Wednesday28/	10.01 - 11.00	2,066	Wednesday28/	12.01 - 13.00	1,480
	Thursday29/	14.01 - 15.00	1,673	Thursday29/	07.01 - 08.00	1,365
	Friday30/	15.01 - 16.00	1,916	Friday30/	08.01 - 09.00	1,333
INTERNASIONAL	Thursday01/	06.01 - 07.00	376	Thursday01/	10.01 - 11.00	80

	KEBERANGKATAN			KEDATANGAN		
	TANGGAL	JAM	JML. PAX	TANGGAL	JAM	JML. PAX
	Friday02/	17.01 - 18.00	167	Friday02/	09.01 - 10.00	419
	Saturday03/	07.01 - 08.00	211	Saturday03/	-	
	Sunday04/	17.01 - 18.00	151	Sunday04/	10.01 - 11.00	413
	Monday05/	08.01 - 09.00	419	Monday05/	16.01 - 17.00	167
	Tuesday06/	12.01 - 13.00	385	Tuesday06/	09.01 - 10.00	415
	Wednesday07/	17.01 - 18.00	159	Wednesday07/	14.01 - 15.00	367
	Thursday08/	06.01 - 07.00	376	Thursday08/	10.01 - 11.00	48
	Friday09/	17.01 - 18.00	169	Friday09/	09.01 - 10.00	426
	Saturday10/	07.01 - 08.00	208	Saturday10/	-	
	Sunday11/	17.01 - 18.00	169	Sunday11/	10.01 - 11.00	421
	Monday12/	08.01 - 09.00	420	Monday12/	17.01 - 18.00	149
	Tuesday13/	12.01 - 13.00	415	Tuesday13/	09.01 - 10.00	375
	Wednesday14/	17.01 - 18.00	144	Wednesday14/	14.01 - 15.00	409
	Thursday15/	06.01 - 07.00	420	Thursday15/	11.01 - 12.00	116
	Friday16/	17.01 - 18.00	146	Friday16/	09.01 - 10.00	422
	Saturday17/	07.01 - 08.00	186	Saturday17/	-	
	Sunday18/	17.01 - 18.00	139	Sunday18/	14.01 - 15.00	221
	Monday19/	08.01 - 09.00	414	Monday19/	18.01 - 19.00	166
	Tuesday20/	12.01 - 13.00	399	Tuesday20/	09.01 - 10.00	399
	Wednesday21/	08.01 - 09.00	352	Wednesday21/	14.01 - 15.00	415
	Thursday22/	06.01 - 07.00	420	Thursday22/	10.01 - 11.00	91
	Friday23/	18.01 - 19.00	168	Friday23/	09.01 - 10.00	422
	Saturday24/	07.01 - 08.00	235			
	Sunday25/	20.01 - 21.00	156	Sunday25/	12.01 - 13.00	242
	Monday26/	08.01 - 09.00	426	Monday26/	18.01 - 19.00	154
	Tuesday27/	13.01 - 14.00	260	Tuesday27/	09.01 - 10.00	416
	Wednesday28/	17.01 - 18.00	172	Wednesday28/	14.01 - 15.00	401
	Thursday29/	06.01 - 07.00	212	Thursday29/	10.01 - 11.00	74
	Friday30/	17.01 - 18.00	165	Friday30/	09.01 - 10.00	417

	KEBERANGKATAN			KEDATANGAN		
	TANGGAL	JAM	JML. PAX	TANGGAL	JAM	JML. PAX
DOMESTIK	Saturday01/	10.01 - 11.00	1,735	Saturday01/	12.01 - 13.00	1,409
	Sunday02/	14.01 - 15.00	1,613	Sunday02/	12.01 - 13.00	1,461
	Monday03/	10.01 - 11.00	1,552	Monday03/	08.01 - 09.00	1,560
	Tuesday04/	14.01 - 15.00	1,874	Tuesday04/	16.01 - 17.00	1,306
	Wednesday05/	10.01 - 11.00	2,226	Wednesday05/	09.01 - 10.00	1,536
	Thursday06/	16.01 - 17.00	1,614	Thursday06/	12.01 - 13.00	1,397
	Friday07/	10.01 - 11.00	1,823	Friday07/	17.01 - 18.00	1,296
	Saturday08/	14.01 - 15.00	1,548	Saturday08/	13.01 - 14.00	1,516
	Sunday09/	10.01 - 11.00	1,745	Sunday09/	16.01 - 17.00	1,425
	Monday10/	10.01 - 11.00	2,006	Monday10/	12.01 - 13.00	1,272
	Tuesday11/	10.01 - 11.00	1,749	Tuesday11/	14.01 - 15.00	1,565
	Wednesday12/	18.01 - 19.00	1,788	Wednesday12/	11.01 - 12.00	1,459
	Thursday13/	10.01 - 11.00	1,880	Thursday13/	15.01 - 16.00	1,460
	Friday14/	10.01 - 11.00	1,921	Friday14/	12.01 - 13.00	1,726
	Saturday15/	10.01 - 11.00	2,266	Saturday15/	13.01 - 14.00	1,411
	Sunday16/	10.01 - 11.00	2,012	Sunday16/	09.01 - 10.00	1,680
	Monday17/	10.01 - 11.00	1,996	Monday17/	08.01 - 09.00	1,947
	Tuesday18/	10.01 - 11.00	1,605	Tuesday18/	14.01 - 15.00	1,289
	Wednesday19/	10.01 - 11.00	2,060	Wednesday19/	08.01 - 09.00	1,775
	Thursday20/	10.01 - 11.00	1,895	Thursday20/	14.01 - 15.00	1,774
	Friday21/	10.01 - 11.00	1,830	Friday21/	13.01 - 14.00	1,764
	Saturday22/	10.01 - 11.00	1,925	Saturday22/	08.01 - 09.00	1,758
	Sunday23/	10.01 - 11.00	1,894	Sunday23/	08.01 - 09.00	2,141
	Monday24/	16.01 - 17.00	1,257	Monday24/	16.01 - 17.00	1,386
	Tuesday25/	10.01 - 11.00	1,765	Tuesday25/	12.01 - 13.00	1,432
	Wednesday26/	14.01 - 15.00	1,687	Wednesday26/	13.01 - 14.00	1,372
	Thursday27/	16.01 - 17.00	1,657	Thursday27/	16.01 - 17.00	1,346
	Friday28/	15.01 - 16.00	1,660	Friday28/	12.01 - 13.00	1,513
	Saturday29/	10.01 - 11.00	1,839	Saturday29/	07.01 - 08.00	1,469
	Sunday30/	14.01 - 15.00	1,491	Sunday30/	13.01 - 14.00	1,090
	Monday31/	10.01 - 11.00	1,646	Monday31/	09.01 - 10.00	1,134

	KEBERANGKATAN			KEDATANGAN		
	TANGGAL	JAM	JML. PAX	TANGGAL	JAM	JML. PAX
INTERNASIONAL	Saturday01/	07.01 - 08.00	127	Saturday01/	-	
	Sunday02/	19.01 - 20.00	142	Sunday02/	10.01 - 11.00	351
	Monday03/	08.01 - 09.00	392	Monday03/	17.01 - 18.00	148
	Tuesday04/	12.01 - 13.00	370	Tuesday04/	09.01 - 10.00	421
	Wednesday05/	17.01 - 18.00	153	Wednesday05/	14.01 - 15.00	319
	Thursday06/	06.01 - 07.00	363	Thursday06/	10.01 - 11.00	86
	Friday07/	17.01 - 18.00	157	Friday07/	09.01 - 10.00	425
	Saturday08/	06.01 - 07.00	18	Saturday08/	-	
	Sunday09/	17.01 - 18.00	164	Sunday09/	17.01 - 18.00	252
	Monday10/	08.01 - 09.00	241	Monday10/	16.01 - 17.00	170
	Tuesday11/	12.01 - 13.00	177	Tuesday11/	09.01 - 10.00	245
	Wednesday12/	17.01 - 18.00	150	Wednesday12/	16.01 - 17.00	672
	Thursday13/	08.01 - 09.00	298	Thursday13/	10.01 - 11.00	90
	Friday14/	17.01 - 18.00	169	Friday14/	16.01 - 17.00	569
	Saturday15/	07.01 - 08.00	208	Saturday15/	-	
	Sunday16/	18.01 - 19.00	156	Sunday16/	18.01 - 19.00	317
	Monday17/	07.01 - 08.00	320	Monday17/	19.01 - 20.00	176
	Tuesday18/	11.01 - 12.00	140	Tuesday18/	09.01 - 10.00	362
	Wednesday19/	17.01 - 18.00	171	Wednesday19/	17.01 - 18.00	179
	Thursday20/	11.01 - 12.00	99	Thursday20/	10.01 - 11.00	115
	Friday21/	17.01 - 18.00	175	Friday21/	09.01 - 10.00	255
	Saturday22/	07.01 - 08.00	204	Saturday22/	-	
	Sunday23/	18.01 - 19.00	285	Sunday23/	13.01 - 14.00	206
	Monday24/	04.01 - 05.00	408	Monday24/	16.01 - 17.00	150
	Tuesday25/	11.01 - 12.00	195	Tuesday25/	09.01 - 10.00	300
	Wednesday26/	17.01 - 18.00	175	Wednesday26/	16.01 - 17.00	276
	Thursday27/	06.01 - 07.00	425	Thursday27/	11.01 - 12.00	129
	Friday28/	17.01 - 18.00	142	Friday28/	09.01 - 10.00	390
	Saturday29/	07.01 - 08.00	226			
	Sunday30/	17.01 - 18.00	181	Sunday30/	16.01 - 17.00	109
	Monday31/	08.01 - 09.00	420	Monday31/	17.01 - 18.00	64